

**DISPLAY OPERATION
MANUAL
DN-109TH, DN-119TH
AND DN-129TH**



Indice

1.-INTRODUCTION	1-1
2.-GENERAL CHARACTERISTICS	2-1
2.1 Electrical characteristics of DN-109TH visual display units.....	2-1
2.2 Electrical characteristics of DN-119TH visual display units.....	2-2
2.3 Electrical characteristics of DN-129TH visual display units.....	2-3
2.4 Temperature and humidity sensor.	2-4
2.4.1 Dimensions of the probe.....	2-4
3.-INSTALLATION	3-1
3.1 Power.....	3-1
3.2 Connecting the temperature and humidity sensor.....	3-2
4.-FUNCTIONING	4-1
4.1 Initial start up.....	4-1
4.2 Programming parameters.....	4-1
4.2.1 Entering to modify paramets.....	4-2
4.2.2 Exiting after modifying parameters.....	4-2
4.2.3 Function of each parameter.....	4-2

CE DECLARATION OF CONFORMITY

1. Introduction.

The numerical visual display units of the **DN-109TH, DN-119TH y DN-129TH series**, are industrial devices for seeing the temperature and/or humidity. The selection of the magnitude is carried out by means of a couple of buttons with an easily programmed code scheme.

One of the main characteristics is the large size of the characters.

DN-109TH of **57mm** with reading from 30m.

DN-119TH of **100 mm** with reading from 50m.

DN-129TH of **250 mm** with reading from 100m.

Just like other series of visual display units, the **DN-109TH, DN-119TH and DN-129TH series**, is also available in versions with one or two faces, which provides for multiple solutions and installation options.

Installation is on a surface, fixed to the wall or partition wall, or suspended from lateral anchor points. The temperature and humidity sensor is located on a base that provides IP67 protection and facilitates installation in any position.

The field of application of these screens is very wide in all kinds of industrial applications, functioning as a thermometer, hygrometer or both magnitudes.

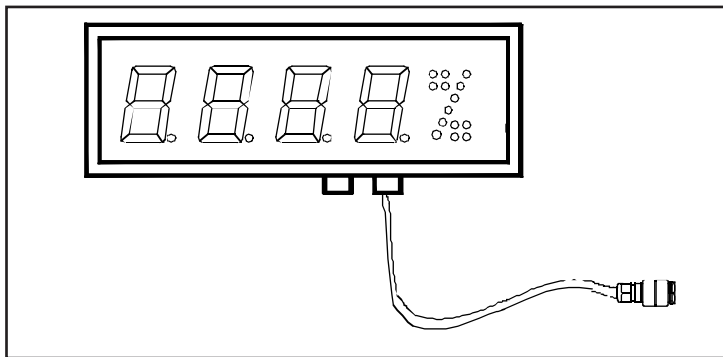

2. Electrical characteristics of the DN-109TH, DN-119TH and DN-129TH.

2.1 Electrical characteristics of the DN-109TH.

Power	100 VAC to 240 VAC	50/60Hz
Consumption	1 Face = 13VA.	
.....	2 Faces = 29 VA	
Display	7 segments of 57mm height plus decimal point.	
.....	Red LED. Visibility 30 metres.	
«°» and «%»symbols	Made up of LED of 3mm diameter	
Parameters	Eeprom.	
Temperature sensor		
Resolution	0,1°C	
Precisión	±0,5° at 25°C	
Response time	20 s	
Working range	-20°C to 80°C	
Humidity sensor		
Resolution	1%	
Precision	±3,5% between 30% and 70%	
Response time	4s	
Environmental conditions		
DN-109TH	Working temperature: 0 to 50°C.	
.....	Storage temperature: -10°C to 60°C	
.....	Humidity 5-95% without condensation.	
.....	Maximum environmental illumination: 1000 lux.	
.....	Protection: DN-109/TH: IP41.	
.....	Temperature / Humidity sensor: IP67	

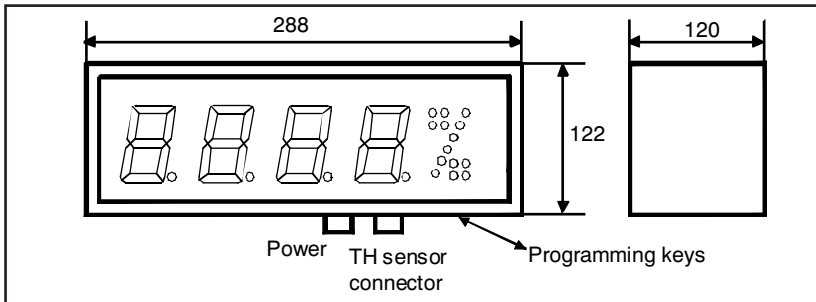

2.1 Dimensions of the DN-109TH visual display unit

2.2 Electrical characteristics of the DN-119TH visual display units.

Power	100 VAC to 240 VAC 50/60Hz
Consumption	1 Face = 15VA.
Display	2 Faces = 29 VA
.....	7 segments of 100mm height plus decimal
.....	point. Red LED. Visibility 50 metres.
«°» and «%»symbols	Made up of LED of 3mm diameter
Parameters	Eeprom.
Temperature sensor	
Resolution	0,1°C
Precisión	±0,5° at 25°C
Response time	20 s
Working range	-20°C to 80°C
Humidity sensor	
Resolution	1%
Precision	±3,5% between 30% and 70%
Response time	4s
Environmental conditions	
DN-119TH	Working temperature: 0 to 50°C.
.....	Storage temperature: -10°C to 60°C
.....	Humidity 5-95% without condensation.
.....	Maximum environmental illumination: 1000 lux.
.....	Protection: DN-119/TH: IP41.
.....	Temperature / Humidity sensor: IP67

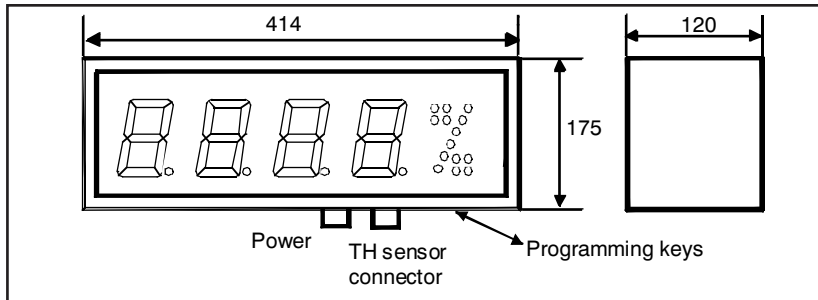

2.2 Dimensions of the DN-119TH visual display unit.

2.3 Electrical characteristics of the DN-129TH visual display units.

Power	100 VAC to 240 VAC 50/60Hz
Consumption	1 Face = 15VA.
Display	2 Faces = 29 VA
.....	7 segments of 250mm height plus decimal
.....	point. Red LED. Visibility 100 metres.
«°» and «%»symbols	Made up of LED of 3mm diameter
Parameters	Eeprom.
Temperature sensor	
Resolution	0,1°C
Precisión	±0,5° at 25°C
Response time	20 s
Working range	-20°C to 80°C
Humidity sensor	
Resolution	1%
Precision	±3,5% between 30% and 70%
Response time	4s
Environmental conditions	
DN-119TH	Working temperature: 0 to 50°C.
.....	Storage temperature: -10°C to 60°C
.....	Humidity 5-95% without condensation.
.....	Maximum environmental illumination: 1000 lux.
.....	Protection: DN-129/TH: IP41.
.....	Temperature / Humidity sensor: IP67

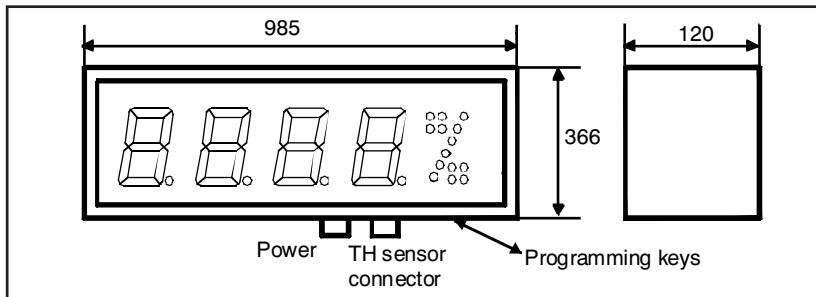

2.3 Dimensions of the DN-129TH visual display unit.

2.4 Temperature and humidity sensor.

The temperature and humidity sensor is located in a piece of black nylon and protected by a membrane which permits humidity to pass but not water. The connection cable enters by a press stop. The set should not be handled so as to maintain IP67 watertightness.

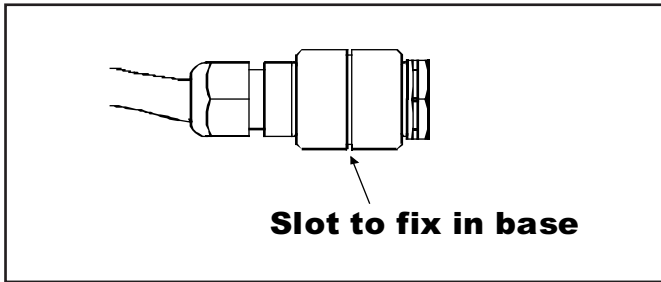

In order to attach it, a clip-type base is supplied. In order to open it, introduce a flat screwdriver through the slot marked «Open» and press slightly outwards and pull upwards. Once you have attached the base, place the sensor on the clip in such a way that the slot of the sensor coincides with the protection of the clip. Close the clip and you will have the sensor in place.

2.4.1 Dimensions of the sensor (mm)

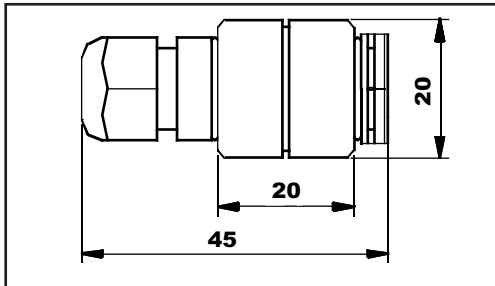

3. Installation

The installation of the DN-109TH, DN-119TH and DN-129TH is not especially delicate but it is necessary to bear in mind certain important considerations.

They must not be anchored in places that are subject to vibration, nor in places which in general are beyond the limits specified in the characteristics of the visual display unit regarding temperature and humidity.

The degree of protection of the DN-109TH, DN-119TH AND DN-129TH visual display units is IP41, which signifies that they are protected against any penetration of foreign solid objects of a diameter greater than 1mm, and against the vertical falling of water droplets.

The DN-109TH, DN-119TH and DN-129TH visual display units must not be installed in places where the level of illumination is greater than 1000 lux. Direct sunlight should also not be allowed to fall on the display as we would then lose visibility.

In the electrical installation, proximity to lines through which very high voltages are flowing, high-voltage lines as well as High Frequency Generators and the U/F converters for cars should be avoided.

3.1 Power.

The power supply should be **100VAC to 240VAC, 50/60 Hz.**

The protection fuse that the equipment includes is **2A**. If for any reason it were necessary to replace the fuse, a fuse of greater calibre should never be used.

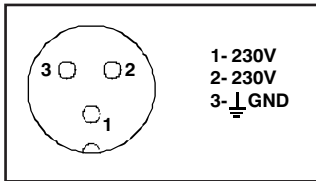

3.1 Power 230VAC

The section of the power conductors will be in accordance with consumption. The earth conductor will have a minimum section of 1.5 mm². Although the visual display units are especially ready for surroundings with a high degree of electrical noise, in the case that there is a suspicion that the power supply line is very noisy, we would advise you to put transformers-separator between the power supply line and the visual display unit and/or to interpose an external field filter.

The power supply connector has three contacts and is situated in the upper part of the device. The connection must be carried out in accordance with figure 3.1

3.2 Connecting the temperature and humidity sensor.

The temperature and humidity sensor is supplied with five metres of cable and with a type DB9 connector which is ready to be connected to the visual display unit.

In case you should have to dismantle the connector, the connections are as follows.

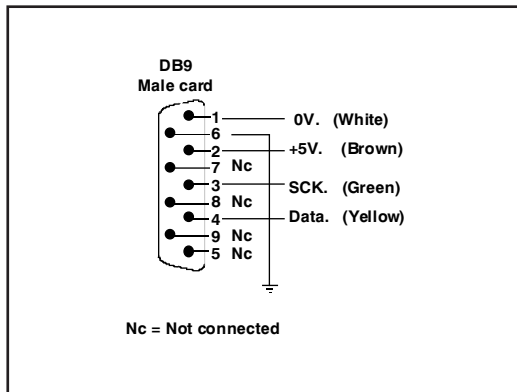

SERIAL CONNECTOR DN-109TH, DN-119TH and DN-129TH

The connector of the cable must be DB9 male.

4. FUNCTIONNING

4.1 Initial start up.

Before connecting the visual display unit to the mains supply, we must ensure that all of the connections have been carried out correctly and that the visual display unit is firmly attached.

Every time that we connect the visual display unit to the mains supply, there is an initial Reset with a test of all of the segments that make up the visual display unit. The test consists of the sequential illumination of all of the digits with the value «8», all of the digits with the value «0» and finally all of the decimal points illuminated. After this point, the programmed magnitude will be seen.

4.2 Programming of parameters.

The DN-109TH, DN-119TH and DN-129TH visual display units may be adapted to the specifications of each client by means of programming the parameters. In this device, the only parameter that can be set is the magnitude to be displayed.

- 1- Magnitude to be displayed.
- 2- Exit modify parameters.

For programming parameters, three digits are used from the right of the visual display unit. The third digit on the right, which is identified as it has the decimal point activated, indicates the number of the parameter and the two digits on the right the value of the parameter. The digit which is flashing is the one that can be modified.

4.2.1 Entering to modify parameters.

In order to enter into the sequence for modifying parameters, it is necessary to press and keep pressed the key advance "7-> 5 for three seconds. Once this time has passed, the first parameter is displayed showing the digit flashing.

From this moment, there are two options:

1- To modify the values of the parameter:

By means of the advance key, the values and the number of the parameter may be correlatively selected.

In order to modify the selected digit, it is necessary to press the «+» key which will increase the value of the selected digit until it reaches its maximum value. It passes to its minimum value upon the next press.

2- To select another parameter.

In order to select another parameter, it is necessary to select (by making it flash) the third digit, by means of the "7->5" key and then to select the new parameter by means of the «+» key.

4.2.2 Exiting modify parameters.

In order to leave the modify parameters sequence it is necessary to select the parameter number 9 and then press "7->5".

4.2.3 The function of each parameter.

4.2.3.1 Parameter 1: Magnitude to be displayed.

It permits the magnitude to be displayed to be set according to the following values.

Code 01: View the temperature.

Code 02: View the humidity.

Code 03: View the temperature and the humidity alternately. The change is made every three seconds.

4.2.3.2 Parameter 2: Exiting modify parameters.

Permits you to leave the modify parameters menu.

EC DECLARATION OF CONFORMITY



Tetralec S.L.
c/ Severo Ochoa, 80
Polígono Industrial Coll de la Manyà
08400 Granollers

As constructor of the device of the **LARTET** brand:
Numerical display with the serial connection.
Model : DN-109TH in all its versions.
Model : DN-119TH in all its versions.
Model : DN-129TH in all its versions.

We declare under our sole responsibility that the above mentioned product is in accordance with the following European directives.

Directive: 73/23/CEE Low voltage directive.
Norm EN61010-1 Safety in electrical equipment.

Directive: 89/336/CEE
Norm UNE-EN 50081-2 Generic norm on emissions. Industrial environment.
Norm UNE-EN 50082-2 Generic norm on immunity. Industrial environment.

Granollers, 15 may 2003

Josep M^a Bisbe
Technical Director