

DISPLAY OPERATION
MANUAL
DR-105



Indice

<u>1.-INTRODUCTION</u>	1-1
1.1 Presentation	1-1
1.2 Models	1-1
1.3 Package contents	1-2
<u>2.-FEATURES AND INSTALLATION</u>	2-1
2.1 General features	2-1
2.2 Installing and setting up	2-2
2.3 RS-485 connection between a DR-105/X,DR-105/AX,DR-105/THX or DR-105/ATHX, a computer and an Afeisa RS232/422/485	2.4
2.4 RS-485 connection between several DR-105/X, DR-105/AX, DR-105/THX or DR-105/ATHX, for working in master/slave mode	2.5
<u>3. OPERATION</u>	3-1
3.1 Quick guide for establishing parameters	3-1
3.1.1 Example for model DR-105	3-1
3.1.2 Example for model DR-105/A	3-2
3.1.3 Example for model DR-105/ATH	3-3
3.1.4 Example for model DR-105/AX connection to computer	3-4
3.1.5 Example for model DR-105/ATHX. Network send DR-105	3-5
3.1.6 Example for model DR-105/TH	3-6
3.1.7 Example for model DR-105/THX. Network send DR-105	3-7
3.1.8 Example for model DR-105/X. Network reception DR-105	3-8
3.2 Parameters	3-9
3.3 Enter to modify parameters	3-9
3.4 Modifying a parameters	3-9
3.5 Exit modifying parameters	3-9
3.6 Parameters description	3-10
<u>4.-PROTOCOLS</u>	4-1
4.1 L-DR105	4-1
4.2 ASCII	4-5
<u>5.-TRANSMISSION FREQUENCIES</u>	5-1

EC DECLARATION OF CONFORMITY

1 INTRODUCTION.

1-1. Presentation

DR-105 series displays are clocks, thermometers and hygrometers that can be programmed to carry out all the functions in the same device. From the simplest unit, working in autonomous mode, to the most powerful, which always indicates the exact time, the date, the temperature, humidity and acts as the network master, there are 8 different units to choose from.

The reception of time and date is via an FM radio receiver with an RDS decoder. The RDS signal of many transmitters encodes the date and time with a precision within 1 second of error. This precision is more than enough for most applications. The selection of the transmitter is carried out by one of the parameters. The temperature and humidity reading is carried out by means of a digital probe fitted in a housing with an IP67 level of protection.

1-2. Models

The generic name of these displays is DR-105, the option code is added after the / symbol for the different models. (DR-105/)

Models with the A option have an FM tuner for receiving the date and time by decoding an RDS signal.

Models with the TH option have a temperature and humidity probe.

Models with the X option have an RS-485 connection to work on a network.

The models available are summarised in the following table:

	Clock for FM-RDS	Temperature and humidity	Serial line connection
DR-105/A	YES	NO	NO
DR-105/ATH	YES	YES	NO
DR-105/AX	YES	NO	YES
DR-105/ATHX	YES	YES	YES
DR-105/TH	NO	YES	NO
DR-105/THX	NO	YES	YES
DR-105/X	NO	NO	YES
DR-105	NO	NO	NO

1-3. Contents of package

Inside the packing box you should find the following material:

In DR-105/A, DR-105/AX and DR-105/X models.

- 1 DR-105 Display
- 1 Display bracket
- 4 Plastic wall plugs
- 4 Screws for securing the support.
- 1 User manual.

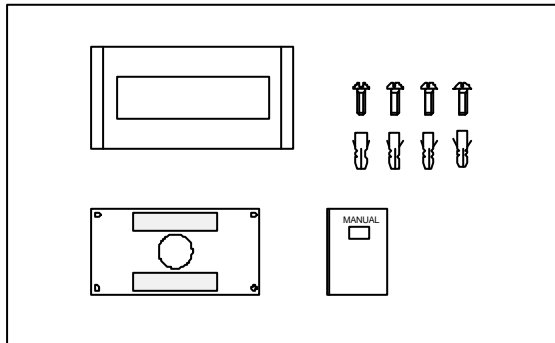

In DR-105/ATH, DR-105/ATHX, DR-105/TH and DR-105/THX models:

- 1 DR-105 Display
- 1 Display bracket
- 5 Plastic wall plugs
- 5 Screws for securing the bracket.
- 1 bracket for the temperature and humidity probe
- 1 User manual.

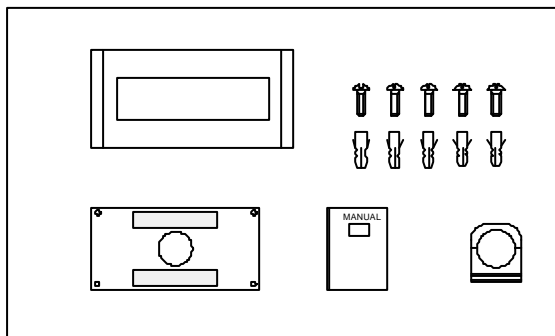

2. FEATURES AND INSTALLATION

2-1. General features.

Power supply:	85 to 264VAC 50/60Hz
Consumption:	10VA
Display:	Dot matrix 25x7 50mm high.
Parameter memory:	Eeprom
Clock accuracy:	±2 s day.
Temperature probe	
Resolution:	0,1°C
Accuracy:	±0,5° to 25°C
Response time:	20 s
Working temp.range:	-20°C to 80°C
Humidit� probe	
Resolution:	1%
Accuracy:	±3,5% between 30% and 70%
Response time:	4 s
Environment conditions	
Working temp. range:	0° to 50°C
Storage temp. range:	-10° to 60°C
Humidit�:	5% to 95% sin condensaci�n.
Maximum environmental illumination:	1000lux
Enclosure protection level	
Front:	IP54
Rear:	IP41
Temperature probe:	IP67
Weight:	1 kg.

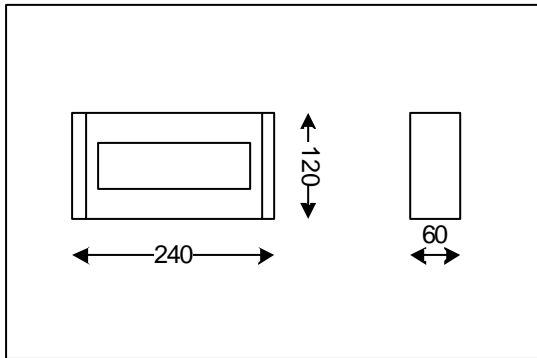

Dimensions

2.2 Installing and setting up

The DR-105 display is really simple to install thanks to its bracket system. The power cable has a Schuko plug, the temperature-humidity probe is connected during manufacturing, and the RS-485 network cable is ready to connect to the network, thus eliminating connection errors.

A bracket is supplied for fixing the DR-105 display to a wall (fasteners and plugs are also supplied) The display is secured to the bracket with Velcro strips. This system facilitates the placement of the viewer, enables alignment problems to be corrected and is adaptable to most brackets.

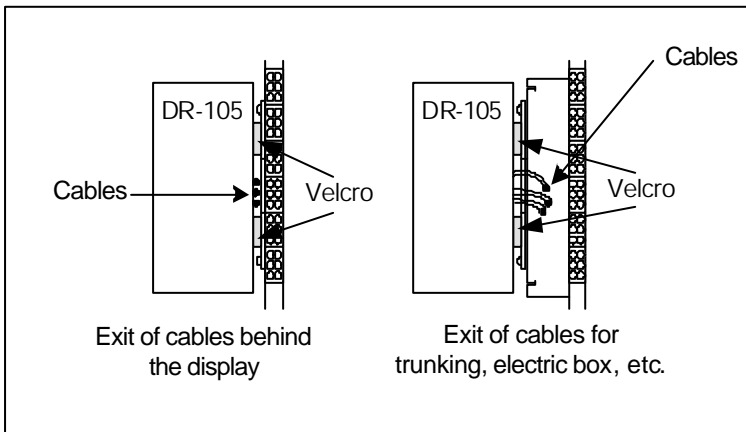

Set-up examples

DR-105 displays should not be used in locations with more than 1000-lux illumination. Neither should there be direct sunlight shining on the display, as this will impair visibility.

2.2.1 Displays with the temperature and humidity option (TH).

To measure temperature and humidity, the display has a probe connected it through a 5 m cable. The probe should be located away from draughts, direct sunlight, air conditioning machines or any other element that could affect the values to be measured.

Location of the probe:

1. The recommended height is 1.5 m above ground level.
2. A plastic bracket is supplied to fit the temperature and humidity probe
3. To open the bracket, insert a screwdriver in the groove marked OPEN and turn the screwdriver in the direction of the arrow (1). Then turn the screwdriver as indicated in (2). The bracket will open on one side (3). Repeat the operation in groove on the other side (4) and the bracket will open completely (5).

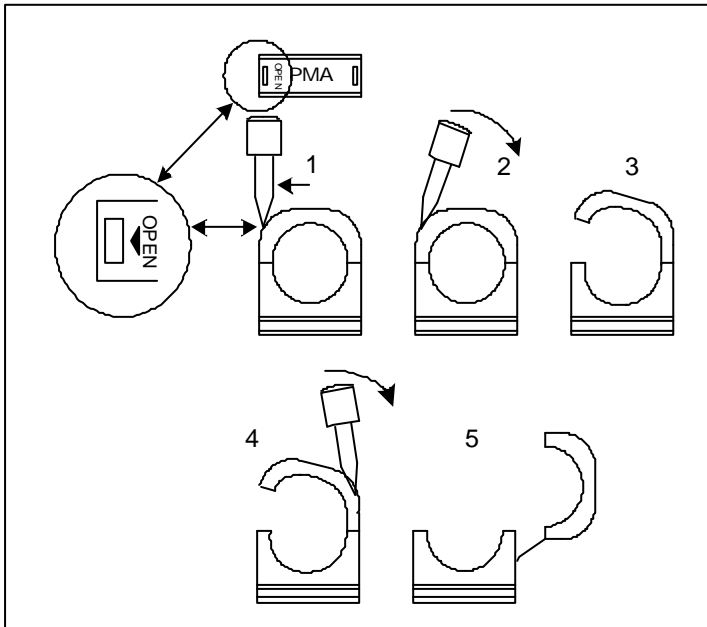

4. Fit the bracket to the wall with the screw and wall plug supplied in the box.
5. Fit the probe to the bracket so that the groove in the probe is in the centre of the bracket. Close the bracket.

2.3 RS-485 Connection between a DR-105/X, DR-105/AX, DR-105/THX or DR-105/ATHX, a computer and an Afeisa RS232/422/485 converter.

In an RS-485 connection, the length of the line must be no more than 1000 m. without using repeaters. It is necessary to use stranded and braided wire, and to connect the cable braid between the converter and the display. When locating the network cables, avoid proximity to power lines.

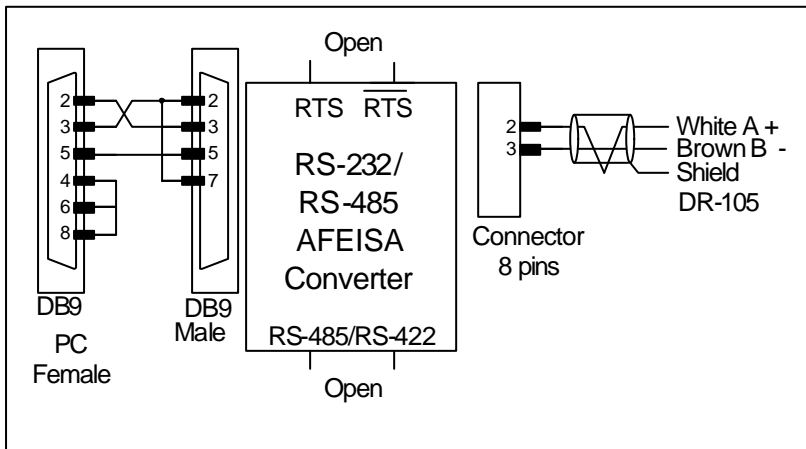

The type of connector (male or female) will correspond to what the cable must have.

2.4 RS-485 connection between several DR-105/X, DR-105/AX, DR-105/THX or DR-105/ATHX, for working in master-slave mode.

In an RS-485 connection, the length of the line must be no more than 1000 m. without using repeaters.

It is necessary to use stranded and braided wire, and to connect the cable braid between the converter and the display. When locating the network cables, avoid proximity to power lines.

In a network it is possible to mix equipment of any of the models DR 105/X, DR- 105/AX, DR-105/THX or DR-105/ATHX, but only one of them can be programmed as network master.

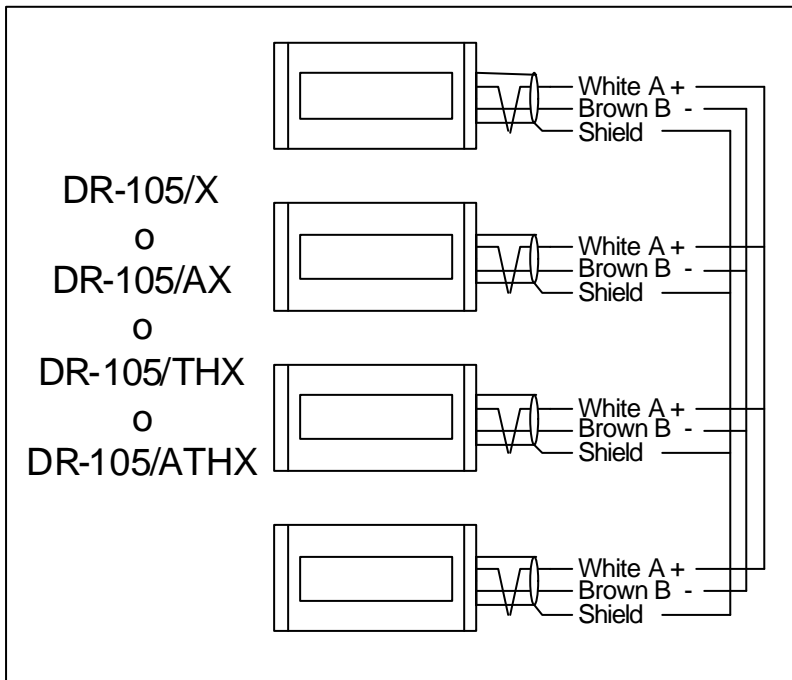

3. OPERATION

3.1 Quick guide for establishing parameters

In this quick guide, you can find some examples for programming the parameters for the most common configurations. If none of the configurations suits your needs, consult parameter adjustment Page 3-9.

Entering to modify parameters: Press key * for 3 seconds. Select parameters with the keys * and +

To exit modifying parameters, select parameter and press key *.

The message: «E P1» means parameter 1 error.

3.1.1 DR-105 Model

Basic model, can only view the date and time. Internal clock.

Parameter 1. Valid values are:

Value	Visualisation
01	Time
08	Date
09	Date + time

Parameter 2. Set the same as 11.

Parameter 3. Do not program. Value unimportant.

Parameter 4. Do not program. Value unimportant.

Parameter 5. Do not program. Value unimportant.

Parameter 6. Do not program. Value unimportant.

Parameter 7. Set the same as 2. To adjust brightness, see param. 7, 8, 9 and 10 in 3.6.

Parameter 8. Set the same as 81. To adjust brightness, see param. 7, 8, 9 and 10 in 3.6.

Parameter 9. Do not program. To adjust brightness, see param. 7, 8, 9 and 10 in 3.6.

Parameter 10. Do not program. To adjust brightness, see param. 7, 8, 9 and 10 in 3.6.

Parameter 11. Set to current time.

Parameter 12. Set current time minutes.

Parameter 13. Set current day date.

Parameter 14. Set current date month.

Parameter 15. Set current date year.

Parameter 16. Do not program. Value unimportant.

Parameter 17. Press * to exit or + to return to modify parameters.

3.1.2 DR-105/A Model

Model with an FM-RDS receiver. It can only display the date and time.

Parameter 1. Valid values are:

Value	Visualisation
01	Time
08	Date
09	Date + time

Parameter 2. Set the same as 12.

Parameter 3. Do not program. Value unimportant.

Parameter 4. Do not program. Value unimportant.

Parameter 5. Do not program. Value unimportant.

Parameter 6. Do not program. Value unimportant.

Parameter 7. Set the same as 2. To adjust brightness, see param. 7, 8, 9 and 10 in 3.6.

Parameter 8. Set the same as 81. To adjust brightness, see param. 7, 8, 9 and 10 in 3.6.

Parameter 9. Do not program. To adjust brightness, see param. 7, 8, 9 and 10 in 3.6.

Parameter 10. Do not program. To adjust brightness, see param. 7, 8, 9 and 10 in 3.6.

Parameter 11. Do not program.

Parameter 12. Do not program.

Parameter 13. Do not program.

Parameter 14. Do not program.

Parameter 15. Do not program.

Parameter 16. Program RDS reception.

1. Select a transmitter in your area, from the tables in chapter 5.
2. Locate the value corresponding to the frequency of the station in the table on page 3.17 and program it in this parameter.
3. Press key * until the parameter number (16) flashes.
4. Check that the antenna cable has been extended.
5. Check the quality of reception. 00: No reception. 92 or more: good reception. If the quality is poor, relocate the antenna.

Parameter 17. Press * to exit or + to return to modify parameters.

3.1.3 DR-105/ATH Model

Model with an FM-RDS receiver and temperature/humidity probe.

Parameter 1. Valid values are:

Value	Visualisation
01	Time
02	Temperature °C
03	Humidity
04	Time + temperature °C
05	Time + humidity
06	Time + temperature °C + humidity
07	Temperature °C + humidity
08	Date
09	Date + time
10	Date + time + temperature °C
11	Date + time + humidity
12	Date + time + temperature °C + humidity
22	Temperature °F
24	Time + temperature °F
26	Time + temperature °F + humidity
27	Temperature °F + humidity
30	Date + time + temperature °F
32	Date + time + temperature °F + humidity

Parameter 2. Set the same as 12.

Parameter 3, 4, 5 and 6. Do not program. Value unimportant.

Parameter 7. Set the same as 2. To adjust brightness, see param. 7, 8, 9 and 10 in 3.6.

Parameter 8. Set the same as 81. To adjust brightness, see param. 7, 8, 9 and 10 in 3.6.

Parameter 9. Do not program. To adjust brightness, see param. 7, 8, 9 and 10 in 3.6.

Parameter 10. Do not program. To adjust brightness, see param. 7, 8, 9 and 10 in 3.6.

Parameter 11, 12, 13, 14 and 15. Do not program.

Parameter 16. Program RDS reception.

1. Select a transmitter in your area, from the tables in chapter 5.
2. Locate the value corresponding to the frequency of the transmitter in the table on page 3.17 and program it in this parameter.
3. Press key * until the parameter number (16) flashes.
4. Check that the antenna cable has been spread out.
5. Check the quality of reception. 00: No reception. 92 or more: good reception. If the quality is poor, relocate the antenna.

Parameter 17. Press * to exit or + to return to modify parameters.

3.1.4 DR-105/AX Model. Connecting to a computer.

Model with a FM-RDS receiver and communication with a computer. It can only view the date and time.

Parameter 1. Valid values are:

Value	Visualisation
01	Time
08	Date
09	Date + time

Parameter 2. Set the same as 15.

Parameter 3. Configuration serial line. For 9600 bauds, 8 bits, even parity and 2 stop bits, set the same as 29. For other values see the table on page 12.

Parameter 4. Network address. To connect to a computer, enter any value.

E.g. = 01.

Parameter 5. Communication protocol. To connect to a computer, it is recommended to set =2. ASCII protocol.

Parameter 6. Do not program. Value unimportant.

Parameter 7. Set the same as 2. To adjust brightness, see param. 7, 8, 9 and 10 in 3.6.

Parameter 8. Set the same as 81. To adjust brightness, see param. 7, 8, 9 and 10 in 3.6.

Parameter 9. Do not program. To adjust brightness, see param. 7, 8, 9 and 10 in 3.6.

Parameter 10. Do not program. To adjust brightness, see param. 7, 8, 9 and 10 in 3.6.

Parameter 11. Do not program.

Parameter 12. Do not program.

Parameter 13. Do not program.

Parameter 14. Do not program.

Parameter 15. Do not program.

Parameter 16. Program RDS reception.

1. Select a transmitter near your area, from the tables in chapter 5.
2. Locate the value corresponding to the frequency of the transmitter in the table on page 3.17 and program it in this parameter.
3. Press key * until the parameter number (16) flashes.
4. Check that the antenna cable has been spread out.
5. Check the quality of reception. 00: No reception. 92 or more: good reception. If the quality is poor, relocate the antenna.

Parameter 17. Press * to exit or + to return to modify parameters.

3.1.5 DR-105/ATHX Model. Network DR-105.

Model with an FM-RDS receiver, temperature/humidity probe and network connection.

Parameter 1. Valid values are:

Value	Visualisation
01	Time
02	Temperature °C
03	Humidity
04	Time + temperature °C
05	Time + humidity
06	Time + temperature °C + humidity
07	Temperature °C + humidity
08	Date
09	Date + time
10	Date + time + temperature °C
11	Date + time + humidity
12	Date + time + temperature °C + humidity
22	Temperature °F
24	Time + temperature °F
26	Time + temperature °F + humidity
27	Temperature °F + humidity
30	Date + time + temperature °F
32	Date + time + temperature °F + humidity

Parameter 2. Set the same as 16.

Parameter 3. Configuration serial line. For 9600 bauds, 8 bits, even parity and 2 stop bits set = 29. For other values, see the table on page 3-12.

Parameter 4. Network address. To synchronise clocks, set = 00.

Parameter 5. Communication protocol. To synchronise clocks it is recommended to set = 1. L-DR105 Protocol.

Parameter 6. Do not program. Value unimportant.

Parameter 7. Set the same as 2. To adjust brightness, see param. 7, 8, 9 and 10 in 3.6.

Parameter 8. Set the same as 81. To adjust brightness, see param. 7, 8, 9 and 10 in 3.6.

Parameter 9. Do not program. To adjust brightness, see param. 7, 8, 9 and 10 in 3.6.

Parameter 10. Do not program. To adjust brightness, see param. 7, 8, 9 and 10 in 3.6.

Parameter 11, 12, 13, 14 and 15. Do not program.

Parameter 16. Program RDS reception.

1. Select a station in your area, from the tables in chapter 5.
2. Locate the value corresponding to the frequency of the station in the table on page 3.17 and program it in this parameter.
3. Press key * until the parameter number (16) flashes.
4. Check that the antenna cable has been extended.
5. Check the quality of reception. 00: No reception. 92 or more: good reception. If the quality is poor, relocate the antenna.

Parameter 17. Press * to exit or + to return to modify parameters.

3.1.6 DR-105/TH Model

Model with a temperature/humidity probe and internal clock.

Parameter 1. Valid values are:

Value	Visualisation
01	Time
02	Temperature °C
03	Humidity
04	Time + temperature °C
05	Time + humidity
06	Time + temperature °C + humidity
07	Temperature °C + humidity
08	Date
09	Date + time
10	Date + time + temperature °C
11	Date + time + humidity
12	Date + time + temperature °C + humidity
22	Temperature °F
24	Time + temperature °F
26	Time + temperature °F + humidity
27	Temperature °F + humidity
30	Date + time + temperature °F
32	Date + time + temperature °F + humidity

Parameter 2. Set the same as 11.

Parameter 3. Do not program. Value unimportant.

Parameter 4. Do not program. Value unimportant.

Parameter 5. Do not program. Value unimportant.

Parameter 6. Do not program. Value unimportant.

Parameter 7. Set the same as 2. To adjust brightness, see param. 7, 8, 9 and 10 in 3.6.

Parameter 8. Set the same as 81. To adjust brightness, see param. 7, 8, 9 and 10 in 3.6.

Parameter 9. Do not program. To adjust brightness, see param. 7, 8, 9 and 10 in 3.6.

Parameter 10. Do not program. To adjust brightness, see param. 7, 8, 9 and 10 in 3.6.

Parameter 11. Set to current time.

Parameter 12. Set current time minutes.

Parameter 13. Set current day date.

Parameter 14. Set current date month.

Parameter 15. Set current date year.

Parameter 16. Do not program. Value unimportant.

Parameter 17. Press * to exit or + to return to modify parameters.

3.1.7 DR-105/THX Model. Network DR-105.

Model with a temperature/humidity probe, internal clock and network communication.

Parameter 1. Valid values are:

Value	Visualisation
01	Time
02	Temperature °C
03	Humidity
04	Time + temperature °C
05	Time + humidity
06	Time + temperature °C + humidity
07	Temperature °C + humidity
08	Date
09	Date + time
10	Date + time + temperature °C
11	Date + time + humidity
12	Date + time + temperature °C + humidity
22	Temperature °F
24	Time + temperature °F
26	Time + temperature °F + humidity
27	Temperature °F + humidity
30	Date + time + temperature °F
32	Date + time + temperature °F + humidity

Parameter 2. Set the same as 13.

Parameter 3. Configuration serial line. For 9600 bauds, 8 bits, parity even and 2 bits stop set = 29. For other values, see the table on page 3-12.

Parameter 4. Network address. To synchronise clocks, set = 00.

Parameter 5. Communication protocol. To synchronise clocks, it is recommended to set = 1. L-DR105 protocol.

Parameter 6. Do not program. Value unimportant.

Parameter 7. Set the same as 2. To adjust brightness, see param. 7, 8, 9 and 10 in 3.6.

Parameter 8. Set the same as 81. To adjust brightness, see param. 7, 8, 9 and 10 in 3.6.

Parameter 9. Do not program. To adjust brightness, see param. 7, 8, 9 and 10 in 3.6.

Parameter 10. Do not program. To adjust brightness, see param. 7, 8, 9 and 10 in 3.6.

Parameter 11. Set current time.

Parameter 12. Set current time minutes.

Parameter 13. Set current day date.

Parameter 14. Set current date month.

Parameter 15. Set current date year.

Parameter 16. Do not program. Value unimportant.

Parameter 17. Press * to exit or + to return to modify parameters.

3.1.8 Model DR-105/X. Network DR-105

Model with an internal clock and network communication.

Parameter 1. Valid values are:

Value	Visualisation
01	Time
02	Temperature °C
03	Humidity
04	Time + temperature °C
05	Time + humidity
06	Time + temperature °C + humidity
07	Temperature °C + humidity
08	Date
09	Date + time
10	Date + time + temperature °C
11	Date + time + humidity
12	Date + time + temperature °C + humidity
22	Temperature °F
24	Time + temperature °F
26	Time + temperature °F + humidity
27	Temperature °F + humidity
30	Date + time + temperature °F
32	Date + time + temperature °F + humidity

Parameter 2. Set the same as 34.

Parameter 3. Configuration serial line. For 9600 bauds, 8 bits, parity even and 2 bits stop set = 29. For other values, see the table on page 3-12.

Parameter 4. Network address. To synchronise clocks, set = 00.

Parameter 5. Communication protocol. To synchronise clocks, it is recommended to set = 1. L-DR105 protocol.

Parameter 6. Do not program. Value unimportant.

Parameter 7. Set the same as 2. To adjust brightness, see param. 7, 8, 9 and 10 in 3.6.

Parameter 8. Set the same as 81. To adjust brightness, see param. 7, 8, 9 and 10 in 3.6.

Parameter 9. Do not program. To adjust brightness, see param. 7, 8, 9 and 10 in 3.6.

Parameter 10. Do not program. To adjust brightness, see param. 7, 8, 9 and 10 in 3.6.

Parameter 11. Do not program. Value unimportant.

Parameter 12. Do not program. Value unimportant.

Parameter 13. Do not program. Value unimportant.

Parameter 14. Do not program. Value unimportant.

Parameter 15. Do not program. Value unimportant.

Parameter 16. Do not program. Value unimportant.

Parameter 17. Press * to exit or + to return to modify parameters.

3-2 Parameters

All parameters are common to all the models. According to the display options, some parameters will not be relevant.

Before using a DR-105 display for the first time, the configuration parameters must be checked. DR-105 displays can work in different ways according to each user's needs. To be adaptable to all users, it is necessary to configure the display.

Some examples of modes of working are: Display the date, time, temperature or humidity and all the combinations that can be made with them (Date and time. Time, temperature and humidity, etc.).

To configure the parameters, the two keys of the front of the device and the display are used. Each parameter is divided into two parts: The parameter number and the value, separated by a decimal point. (NN.VV)

The parameter number can have one or two digits. Range (1 to 17). The values can have one or two digits. Each parameter has its own range.

To modify a value, this must be flashing.

The display keys are identified by the symbols + and *. The key + is used to increase the value of the digit that is flashing. The key * is used to select the digit, which should be flashing.

3-3 Enter to modify parameters.

To enter modify parameters, press key * for more than 3 seconds. You will view parameter 1 with the digit of the parameter (1) flashing.

3-4 Modifying a parameter.

To modify a parameter digit, it must be flashing. Press key * To select the values of the parameter, with the parameter you wish to modify flashing, press key + to modify its value. On reaching the end of the range, it returns to the initial value. Press key * again to select another parameter digit or to return to select the parameter number.

3-5 Exit modify parameters.

To exit modify parameters, select parameter 17 and press *.

Parameter Value

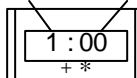

3-6 Parameter Description

Parameter 1.

Parameter 1 enables the selection of the data displayed. The "+" sign indicates that the selected values are displayed consecutively. (Example value = 05 the time and humidity are displayed alternatively). The data is changed every 4 sec.

The format in which the data is viewed is the following:

Time: HH:MM where HH are hours and MM minutes. The colon marks the seconds. 0.5 sec off and 0.5 sec on.

Temperature: TT.T° where T is the temperature in tens, units and tenths of a degree Centigrade or Fahrenheit according to what has been selected.

Humidity: hh % where hh is the humidity in %.

Date: DD/MM/YY where DD is the day, MM is the month and YY are the last two digits of the year. The date is viewed moving from right to left. Values valid from 2000 to 2060.

Value	Visualisation
01	Time
02	Temperature °C
03	Humidity
04	Time + temperature °C
05	Time + humidity
06	Time + temperature °C + humidity
07	Temperature °C + humidity
08	Date
09	Date + time
10	Date + time + temperature °C
11	Date + time + humidity
12	Date + time + temperature °C + humidity
22	Temperature °F
24	Time + temperature °F
26	Time + temperature °F + humidity
27	Temperature °F + humidity
30	Date + time + temperature °F
32	Date + time + temperature °F + humidity

Parameter 2.

Parameter 2 enables the selection of how the data displayed is obtained. The value of parameter, $2.V_1V_2$, have two parts, V_1 corresponds to the control of the temperature and the humidity, and V_2 corresponds to the control of the date and the hour.

Control of the temperature and the humidity, V_1 . For the obtaining of the temperature and humidity can be done by selecting between the following options:

- 1- Temperature and humidity from the built-in probe.
- 2- Temperature and humidity from the built-in probe, network master. Being the network master, it will send the temperature and the humidity on the serial line, so the other equipment displays the same values.
- 3- Temperature and humidity from reception of network data.

Control of the date and time, V_2 . For the obtaining of the date and time can be done by selecting between the following options:

- 1 - Internal clock. The device has an internal oscillator powered by a battery that maintains the date and time. This internal clock is used to maintain the date and time in the case of power cuts.
- 2- FM-RDS receiver. The date and time are obtained from the encoded information in the RDS signal from an FM radio station.
- 3 - Internal clock. Network send DR-105. The same as option 1, but in addition, being the network Master, it will send the date and time on the serial line so the other equipment displays the same values.
- 4- Reception network DR-105. Computer. Receives the date and time through the network. It can also be used to send the date and time of the internal clock (Option 1) to a computer.
- 5- FM-RDS receiver. Computer. It can send the date and time obtained from the FM-RDS receiver (Option 2) to a computer.
- 6- FM-RDS receiver. Network send DR-105. The same as option 2, but in addition, being the network send DR-105, it will send the date and time on the serial line so the other equipment displays the same values.

V_1	Temperature- Humidity	V_2	Clock - Calendar
1	Built-in probe.	1	Internal clock
2	Built-in probe. Network send DR-105	2	FM-RDS receiver
3	Reception network DR-105. Computer	3	Internal clock. Network send DR-105
		4	Reception network DR-105. Computer
		5	FM-RDS receiver. Computer
		6	FM-RDS receiver. Network send DR-105

Table for parameter 2.

Parameter 3. Only for DR-105/AX, DR-105/ATHX, DR-105/THX, DR-105/X models
Configuration of the serial line.

To configure the serial line, use the table on this same page. In parameter 3, program the value indicated in the column "Value" according to the specifications of speed, Data bits, parity and Stop bits that the serial line must have.

Value	Speed	Data bits	Parity	Stop bits	Value	Speed	Data bits	Parity	Stop bits
01	4800	7	NO	1	19	4800	7	NO	2
02	9600	7	NO	1	20	9600	7	NO	2
03	19200	7	NO	1	21	19200	7	NO	2
04	4800	8	NO	1	22	4800	8	NO	2
05	9600	8	NO	1	23	9600	8	NO	2
06	19200	8	NO	1	24	19200	8	NO	2
07	4800	7	EVEN	1	25	4800	7	EVEN	2
08	9600	7	EVEN	1	26	9600	7	EVEN	2
09	19200	7	EVEN	1	27	19200	7	EVEN	2
10	4800	8	EVEN	1	28	4800	8	EVEN	2
11	9600	8	EVEN	1	29	9600	8	EVEN	2
12	19200	8	EVEN	1	30	19200	8	EVEN	2
13	4800	7	ODD	1	31	4800	7	ODD	2
14	9600	7	ODD	1	32	9600	7	ODD	2
15	19200	7	ODD	1	33	19200	7	ODD	2
16	4800	8	ODD	1	34	4800	8	ODD	2
17	9600	8	ODD	1	35	9600	8	ODD	2
18	19200	8	ODD	1	36	19200	8	ODD	2

Parameter 4. Only for models DR-105/AX, DR-105/ATHX, DR-105/THX, DR-105/X
Address in the network.

It enables the configuration of the display address in the network. You can select a value between 00 and 99. They are only used to connect to computers.

Parameter 5. Only for models DR-105/AX, DR-105/ATHX, DR-105/THX, DR-105/X

Value	Protocol
1	L-DR105
2	ASCII

The operation of the protocols is described in chapter 4

Parameter 6.

Reserve. Any value.

Parameter 7.

The brightness control enables you to adjust the brightness of the display according to ambient illumination, to avoid dazzling. There are 8 levels of brightness. Level 0 is the minimum brightness and 8 the maximum.

The following adjustments are possible:

Value	Brightness control
1	Value received by the serial line
2	By parameter 8. Digit of the left
3	Inside a time frame
4	Reserva

1. Value received by the serial line. See protocols.
2. Fixed value programmed in parameter 8. The digit on the left of parameter 8 determines the brightness.
3. Modify the brightness for a certain time frame. Programming is carried out with parameters 8, 9 and 19. Parameter 8 adjusts the brightness and parameters 9 and 10 the time frame.

Program the brightness for a certain time frame.

To adjust the brightness in a time frame, the first thing to do is to define the start and finish times of the time frame. The valid start and finish times are valid in 15-minute intervals. The table on the next page shows the valid start and finish times as well as the code to enter in parameters 9 and 10.

The brightness from the start to finish times (within the time frame) is adjusted in the left-hand side digit of parameter 8. The brightness outside the time frame is adjusted with the digit on the right of parameter 8.

Parameter 8.

Brightness.

	Parameter 7 = 2	Parameter 7 = 3
Digit of the left	Brightness of the equipment	Brightness if the hour is inside the time frame
Digit of the right	It is not in use.	Brightness if the hour is out of the time frame

Parameter 9

Initial time of the time frame for programmed brightness. Parameters 7 and 8; see conversion table on this page.

Parameter 10

End time of the time frame for programmed brightness. Parameters 7 and 8; see conversion table on this page.

Parameter 11

Current time. To modify the time. The time can be modified on leaving the parameter configuration. (Parameter 17)

Parameter 12

Current time minutes. To modify the minutes. The minutes can be modified on leaving the parameter configuration. (Parameter 17)

Parameter 13

Current day. To modify the day. The day can be modified on leaving the parameter configuration. (Parameter 17)

Parameter 14

Current month. To modify the month. The month can be modified on leaving the parameter configuration. (Parameter 17)

Parameter 15

Current year. To modify the year. The year can be modified on leaving the parameter configuration. (Parameter 17)

VALUE	TIME	VALUE	TIME	VALUE	TIME	VALUE	TIME
1	0:00	25	6:00	49	12:00	73	18:00
2	0:15	26	6:15	50	12:15	74	18:15
3	0:30	27	6:30	51	12:30	75	18:30
4	0:45	28	6:45	52	12:45	76	18:45
5	1:00	29	7:00	53	13:00	77	19:00
6	1:15	30	7:15	54	13:15	78	19:15
7	1:30	31	7:30	55	13:30	79	19:30
8	1:45	32	7:45	56	13:45	80	19:45
9	2:00	33	8:00	57	14:00	81	20:00
10	2:15	34	8:15	58	14:15	82	20:15
11	2:30	35	8:30	59	14:30	83	20:30
12	2:45	36	8:45	60	14:45	84	20:45
13	3:00	37	9:00	61	15:00	85	21:00
14	3:15	38	9:15	62	15:15	86	21:15
15	3:30	39	9:30	63	15:30	87	21:30
16	3:45	40	9:45	64	15:45	88	21:45
17	4:00	41	10:00	65	16:00	89	22:00
18	4:15	42	10:15	66	16:15	90	22:15
19	4:30	43	10:30	67	16:30	91	22:30
20	4:45	44	10:45	68	16:45	92	22:45
21	5:00	45	11:00	69	17:00	93	23:00
22	5:15	46	11:15	70	17:15	94	23:15
23	5:30	47	11:30	71	17:30	95	23:30
24	5:45	48	11:45	72	17:45	96	23:45

Conversion tables for the start and finish times of the time frame for programming parameters 9 and 10.

Parameter 16. Only for models DR-105/A, DR-105/ATH, DR-105/AX, DR-105/ATHX
Adjustment of FM-RDS reception.

In models supplied with FM-RDS reception, the date and time are adjusted automatically from the RDS signal transmitted via FM stations. To receive the signal, the equipment must be tuned to a station transmitting this type of signal. Parameter 16 enables you to adjust the reception frequency and evaluate the quality of reception.

To adjust FM-RDS reception, do the following:

1. Make sure that the antenna is correctly spread out. The antenna cable comes from the rear of the device and has a diameter of approx. 1 mm. On extending the antenna, avoid proximity with the power supply cable (220V). A horizontal position will give better results.
2. Look for the nearest stations in annexe A. Take into account that not all the stations are valid. Before selecting a station, the following should be taken into account:

NOT all FM stations transmit the RDS signal.

Of the stations that do transmit the RDS signal, NOT all of them send the time and date encoded.

Of the stations that encode the time and date, NOT all of them transmit it correctly.

The data required from the station is the frequency used for the transmission. The networks and transmitters that have been verified are:

Network: Radio Nacional de España

Broadcasters: Radio 1, Radio Clásica, Radio 3 and Radio 4

Network: Catalunya Radio

Stations: Catalunya Radio, Catalunya Cultura, Cat. Musica and Cat. Informació.

The station frequencies can also be found in newspapers.

Example for a device located in the city of Barcelona. Station Radio 1. Centro transmitter Collserola. Frequency 88.3 MHz.

3. With the station frequency, go to the table on page 3-8 and locate the value corresponding to this frequency.
Example: For 88.3 MHz the corresponding value is 09.
4. Program the value obtained in the table in parameter 16.
Example: In parameter 16, program value 09.
5. Check reception quality. To check reception quality select parameter 16 so that the value 16 is flashing. (Using key *). From that moment the digits of the value indicate reception quality.

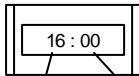

Parameter	Value		Quality level of the reception
16	0	0	There is no reception
16	Variable	0	Insufficient quality of reception
16	Variable	2	Few quality. It is possible to tune
16	9	>4	Good quality

If good quality is not obtained, try moving the antenna or selecting another station. To check that the quality is sufficient, go to parameter 11 and modify the current time. Then go to parameter 17 to exit modify parameters. If the current time has not been adjusted within five minutes, the quality is insufficient. Select another station or move the antenna.

Value	Freq.	Value	Freq.	Value	Freq.	Value	Freq.	Value	Freq.	Value	Freq.	Value	Freq.
		20	90,6	40	93,8	60	97,0	80	100,2	A0	103,4	C0	106,6
01	87,5	21	90,7	41	93,9	61	97,1	81	100,3	A1	103,5	C1	106,7
02	87,6	22	90,8	42	94,0	62	97,2	82	100,4	A2	103,6	C2	106,8
03	87,7	23	90,9	43	94,1	63	97,3	83	100,5	A3	103,7	C3	106,9
04	87,8	24	91,0	44	94,2	64	97,4	84	100,6	A4	103,8	C4	107,0
05	87,9	25	91,1	45	94,3	65	97,5	85	100,7	A5	103,9	C5	107,1
06	88,0	26	91,2	46	94,4	66	97,6	86	100,8	A6	104,0	C6	107,2
07	88,1	27	91,3	47	94,5	67	97,7	87	100,9	A7	104,1	C7	107,3
08	88,2	28	91,4	48	94,6	68	97,8	88	101,0	A8	104,2	C8	107,4
09	88,3	29	91,5	49	94,7	69	97,9	89	101,1	A9	104,3	C9	107,5
0A	88,4	2A	91,6	4A	94,8	6A	98,0	8A	101,2	AA	104,4	CA	107,6
0B	88,5	2B	91,7	4B	94,9	6B	98,1	8B	101,3	AB	104,5	CB	107,7
0C	88,6	2C	91,8	4C	95,0	6C	98,2	8C	101,4	AC	104,6	CC	107,8
0D	88,7	2D	91,9	4D	95,1	6D	98,3	8D	101,5	AD	104,7	CD	107,9
0E	88,8	2E	92,0	4E	95,2	6E	98,4	8E	101,6	AE	104,8	CE	108,0
0F	88,9	2F	92,1	4F	95,3	6F	98,5	8F	101,7	AF	104,9		
10	89,0	30	92,2	50	95,4	70	98,6	90	101,8	B0	105,0		
11	89,1	31	92,3	51	95,5	71	98,7	91	101,9	B1	105,1		
12	89,2	32	92,4	52	95,6	72	98,8	92	102,0	B2	105,2		
13	89,3	33	92,5	53	95,7	73	98,9	93	102,1	B3	105,3		
14	89,4	34	92,6	54	95,8	74	99,0	94	102,2	B4	105,4		
15	89,5	35	92,7	55	95,9	75	99,1	95	102,3	B5	105,5		
16	89,6	36	92,8	56	96,0	76	99,2	96	102,4	B6	105,6		
17	89,7	37	92,9	57	96,1	77	99,3	97	102,5	B7	105,7		
18	89,8	38	93,0	58	96,2	78	99,4	98	102,6	B8	105,8		
19	89,9	39	93,1	59	96,3	79	99,5	99	102,7	B9	105,9		
1A	90,0	3A	93,2	5A	96,4	7A	99,6	9A	102,8	BA	106,0		
1B	90,1	3B	93,3	5B	96,5	7B	99,7	9B	102,9	BB	106,1		
1C	90,2	3C	93,4	5C	96,6	7C	99,8	9C	103,0	BC	106,2		
1D	90,3	3D	93,5	5D	96,7	7D	99,9	9D	103,1	BD	106,3		
1E	90,4	3E	93,6	5E	96,8	7E	100,0	9E	103,2	BE	106,4		
1F	90,5	3F	93,7	5F	96,9	7F	100,1	9F	103,3	BF	106,5		

Parameter 17

Exit parameter configuration. By pressing key * you end parameter programming.

If the time or minutes have been modified, on leaving parameter configuration the clock will be updated. The seconds will begin at zero.

4. - PROTOCOLS

Information transfer between devices is one of the advantages of incorporating powerful controllers in the equipment. However, to transfer information, some conditions must be met. Firstly, there must be a physical link by cable or radio. Secondly, there must be a communication protocol enabling the equipment to work together. And finally, this information transferred must also follow some regulations.

For communication between DR-105 equipment, an RS-485 link is used; enabling distances of up to 1000m without repeaters and up to 32 networked devices. Two protocols are available: L-DR105 and ASCII. The most important difference between them is that the L-DR105 uses an error control to check the data transmitted, while the ASCII does not.

Only for DR-105/AX, DR-105/ATHX, DR-105/THX and DR-105/X models

4.1 L-DR105 protocol.

Communication can be established in two ways: The DR-105 acting as master or the DR-105 acting as a slave.

-Network send DR-105 mode. Parameter 2 = 13 or 16. Parameter 5 = 1.

Every 60 seconds, coinciding to the value of seconds =0, the date and time information is transmitted.

Every 5 seconds, except when the value of the seconds =0, the temperature and humidity values are transmitted.

The Network send DR-105 mode can only be used to synchronise several DR-105 devices. The receiving device can be programmed to display the date and time received, the temperature and humidity received, or the date, time, temperature and humidity data received.

Thus, it is possible to program the device to display information received from the network or collected independently.

Example: Network send DR-105 mode.

Parameter 2 = 13. Obtains the date and time from the internal clock and the temperature and humidity from the device's own probe.

Parameter 2 = 16. Obtains the date and time from the RDS tuner and the temperature and humidity from the device's own probe.

In versions without a temperature and humidity probe, in the information corresponding to temperature and humidity, value 0 is sent.

- Reception network DR-105 mode. Computer. Parameter 2 = 14, 15, 34 or 35. Parameter 5 = 1.

To access the clock data from a computer, it is necessary to send a frame for data request. On receiving a request, the DR-105 responds with the information on date, time, temperature in degrees centigrade, temperature in degrees Fahrenheit, relative air humidity and display brightness.

Data request frame from the computer to DR-105

Heading		Address		Num	Code	CRC	CRC	End of frame	
00h	02h	dd	hh	05h	21h	Impair	Pair	00h	03h

Heading: Always the values 00h and 02h. (h = in hexadecimal)

Address: The address of the DR-105 in the network. Values valid between 0 and 99. (00h and 63h)

Num: Number of characters of the frame. Always 05h.

Code: Data request code. Always 21h.

CRC odd: 1 Byte. It is the result of calculating the OR-exclusive function from the byte Address from the byte previous to the CRC.

CRC even: 1 Byte. It is the result of calculating the OR-exclusive function from the byte Num to the byte previous to the CRC.

End of frame: 2 Bytes. Always the pair of bytes 00h and 03h. (h = in hexadecimal)

Response frame sent by the DR-105 to the computer.

Heading		Address		Num	Code	Day		Month		Year		Space
00h	02h	00h	26h	20h	1Ch	dD	uD	dM	uM	dA	uA	20h

Time		Minute		Second		Code		Temperature °C			Code		Temperature °F				
dH	uH	dM	uM	dS	uS	20h	1Eh	dT	uT	.	mT	20h	1Fh	dT	uT	.	mT

Code		Humidity		Code		Brightness		CRC	CRC	End of frame	
20h	21h	dH	uH	20h	22h	L	Impair	Pair	00h	03h	

Heading: Always the values 00h and 02h. (h = in hexadecimal)

Address: The network address of the DR-105. Values valid between 0 and 99. (00h and 63h)

Num: Number of characters of the frame. Always 26h.

Code: Date and year response code. Always 20h 1Ch.

Date and time: The date and time is distributed in 13 bytes according to the following details:

Day: dD = Ten unit of day. uD = Unit of day. In ASCII code.

Month: dM = Tens of month. uM = Units of month. In ASCII code.

Year: dA = Tens of year. uA = Units of year. In ASCII code.

Space = Blank space. Code 20 ASCII.

Time: dH = Tens of time. uH = Units of time. In ASCII code.

Minute: dM = Tens of minute. uM = Units of minute. In ASCII code.

Second: dS = Tens of second. uS = Units of second. In ASCII code.

Code: Response code for temperature in degrees Centigrade. Always 20h 1Eh

Temperature °C: The temperature in degrees centigrade is distributed in 4 bytes, according to the following details:

Temperature: dT = Tens temperature. uT = Units temperature. Decimal point always code 2E ASCII. mT = Tenths of degree.

Code: Response code for temperature in degrees Fahrenheit. Always 20h 1Fh

Temperature °F: The temperature in degrees Fahrenheit is distributed in 4 bytes, according to the following details:

Temperature: dT = Tens temperature. uT = Units temperature. Decimal point always code 2E ASCII. mT = Tenths of degree.

Code: Humidity response code. Always 20h 21h

Humidity: The humidity is distributed in 2 bytes, according to the following details:

Humidity: dH = Tens humidity. uH = Units humidity.

Code: Brightness response code. Always 20h 21h

Brightness: Brightness occupies 1 byte.

CRC odd: 1 Byte. It is the result of calculating the OR-exclusive function from the byte Address from the byte previous to the CRC.

CRC even: 1 Byte. It is the result of calculating the OR-exclusive function from the byte Num to the byte previous to the CRC.

End of frame: 2 Bytes. Always the pair of bytes 00h and 03h. (h = in hexadecimal)

Example:

Reading the data of the DR-105 in address 00.

Computer data request:

Heading		Address		Num	Code	CRC		End of frame	
00	02	00	05	21	21	05	00	03	

DR-105 response:

Heading		Address		Num	Code		Day		Month		Year		Space
00	02	00	26	20	1C	31	32	30	34	30	33	20	

Time		Minute		Second		Code		Temperature °C		Code		Temperature °F					
31	37	34	33	35	32	20	1E	32	34	2E	38	20	1F	37	36	2E	36

Code		Humidity		Code		Brightness		CRC		End of frame	
20	21	35	38	20	22	38	31	37	00	03	

Data read:

Day = 12. Month = 04. Year = 03. (2003)

Time = 17. Minute = 43. Second = 52.

Temperature in degrees Centigrade = 24.8°C.

Temperature in degrees Fahrenheit = 76.6 °F.

Humidity = 58%

Brightness = 8. (Maximum).

4.2 ASCII Protocol.

Communication can be established in two ways: The DR-105 acting as master or the DR-105 acting as a slave.

-Network send DR-105 mode. Parameter 2 = 13 or 16. Parameter 5 = 2.

Every 60 seconds, coinciding to the value of seconds =0, the date and time information is transmitted.

Every 5 seconds, except when the value of the seconds =0, the temperature and humidity values are transmitted.

The network send DR-105 mode can only be used to synchronise several DR-105 devices. The receiving device can be programmed to display the date and time received, the temperature and humidity received, or the date, time, temperature and humidity data received.

Thus, it is possible to program the device to display information received from the network or collected independently.

Example: Reception network DR-105 mode.

Parameter 2 = 13. Obtains the date and time from the internal clock and the temperature and humidity from the device's own probe.

Parameter 2 = 16. Obtains the date and time from the RDS tuner and the temperature and humidity from the device's own probe.

In versions without a temperature and humidity probe, in the information corresponding to temperature and humidity, value 0 is sent.

- Reception network DR-105 mode. Computer. Parameter 2=14,15,34 or 35. Parameter 5=1.

To access the clock data from a computer, it is necessary to send a data request frame. On receiving the request, the DR-105 responds with information on the date, temperature in degrees Centigrade, temperature in degrees Fahrenheit, relative air humidity and display brightness.

Data request frame from the computer to DR-105

Heading	Address		Code		End of frame	
@	Da	Db	A	C	*	CR

Heading: Always the character @. (40 = in hexadecimal)

Address: The network address of the DR-105. Da high value. Db low value. Valid values between 0 and 99. (30 30 and 39 39 in hexadecimal.)

Code: Data request code. Always the characters A C (41 43 in hexadecimal).

End of frame: 2 Bytes. Always the pair of bytes * and CR. (2A 0D in hexadecimal).

Response frame sent by the DR-105 to the computer.

Heading		Address		Code		Day		Month		Year		Space
@		Da	Db	A	C	dD	uD	dM	uM	dA	uA	20h

Time		Minute		Second		Code		Temperature °C		Code		
dH	uH	dM	uM	dS	uS	20h	1Eh	dT	uT	.	mT	20h 1Fh

Temperature °F				Code		Humidity		Code		Brightness		Enf of frame	
dT	uT	.	mT	20h	21h	dH	uH	20h	22h	L		*	CR

Heading: Always the character @. (40 = in hexadecimal)

Address: The network address of the DR-105. Da high value. Db low value. Valid values between 0 and 99. (30 30 and 39 39 in hexadecimal.)

Code: Data request code. Always the characters A C (41 43 in hexadecimal).

Date and time: The date and time is distributed in 13 bytes according to the following details:

Day: dD = Ten unit of day. uD = Unit of day. In ASCII code.

Month: dM = Tens of month. uM = Units of month. In ASCII code.

Year: dA = Tens of year. uA = Units of year. In ASCII code.

Space = Blank space. Code 20 ASCII.

Time: dH = Tens of time. uH = Units of time. In ASCII code.

Minute: dM = Tens of minute. uM = Units of minute. In ASCII code.

Second: dS = Tens of second. uS = Units of second. In ASCII code.

Code: Response code for temperature in degrees Centigrade. Always 20h 1Eh

Temperature °C: The temperature in degrees Centigrade is distributed in 4 bytes, according to the following details:

Temperature: dT = Tens temperature. uT = Units temperature. Decimal point always code 2E ASCII. mT = Tenths of degree.

Code: Response code for temperature in degrees Fahrenheit. Always 20h 1Fh

Temperature °F: The temperature in degrees Fahrenheit is distributed in 4 bytes, according to the following details:

Temperature: dT = Tens temperature. uT = Units temperature. Decimal point always code 2E ASCII. mT = Tenths of degree.

Code: Humidity response code. Always 20h 21h

Humidity: The humidity is distributed in 2 bytes, according to the following details: Humidity: dH = Tens humidity. uH = Units humidity.

Code: Brightness response code. Always 20h 21h

Brightness: Brightness occupies 1 byte.

End of frame: 2 Bytes. Always the pair of bytes * and CR. (2A 0D in hexadecimal).

Example:

Reading the data of the DR-105 in address 05.

Computer data request

Heading	Address		Code		End of frame	
40	30	35	41	43	2A	0D

 Hexadecimal

DR-105 response:

Heading	Address		Code		Day		Month		Year		Space
40	30	30	41	43	32	37	31	30	30	33	20

Time		Minute		Second		Code		Temperature °C			Code		
31	35	30	39	32	38	20	1E	31	38	2E	33	20	1F

Temperature °F				Code		Humidity		Code		Brightness	Enf of frame	
36	34	2E	39	20	21	36	34	20	22	38	*	CR

Data read:

Day = 27. Month = 10. Year = 03. (2003)

Time = 15. Minute = 09. Second = 28.

Temperature in degrees Centigrade = 18.3°C.

Temperature in degrees Fahrenheit = 64.9 °F.

Humidity = 64%

Brightness = 8. (Maximum).

5. - TRANSMISSION FREQUENCIES

The following pages indicate the transmission frequencies of Radio Nacional de España (RNE) and the group of stations of Catalunya Radio stations, transmitting the RDS signal with encoded date and time. To select a station outside the community of Catalonia, it is necessary to use an RNE group station.

RNE stations are grouped by Autonomous Communities and within each community, by provinces, if they exist. First select the Autonomous Community, then the province (if applicable), the nearest transmitter to the location of the equipment, and finally the frequency of one of the stations.

The stations in the Catalunya Radio group are divided into districts. Select the nearest transmitter to the location of the equipment, and finally select the frequency of one of the stations.

For each location it will be necessary to search for the best station. There is no rule to establish the transmitter that will give the best results.

DECLARATION OF CONFORMITY

Tetralec S.L.
c/ Severo Ochoa, 80
Poligono Industrial Coll de la Manya
08400 Granollers

As the manufacturer of the brand **LARTET** equipment:

Numeric display with serial interface.
Model: DR-105 in all versions.

We state under own responsibility that the above mentioned product
complies with the following European:

Regulation: 73/23/CEE Regulation of low voltage
Standard UNE-EN61010-1 Security in electric equipment

Regulation: 89/336/CEE Regulation of electromagnetic compatibility
Standard UNE-EN61000-6-4 Generic emission standard.Industrial
environment
Standard UNE-EN61000-6-2 Generic immunity standard.Industrial
environment

Granollers, 28 of June 2004

Josep M^a Bisbe
Technic Manager

