

OPERATION MANUAL
FOR DISPLAYS OF
SERIES DN-109AT, DN-119AT, DN-129AT and DN-189AT



Index

<u>1-INTRODUCTION</u>	1
1.1 Model reference structure	2
<u>2-GENERAL SPECIFICATIONS</u>	3
2.1 Electrical characteristics of DN-109AP	3
2.1.1 Environmental conditions of displays DN-109AT	4
2.1.2 Dimensions of displays DN-109AT	5
2.1.3 Displays weight DN-109AT	5
2.2 Electrical characteristics of DN-119AT	6
2.2.1 Environmental conditions of DN-119AT	7
2.2.2 Dimensions of displays DN-119AT	8
2.2.3 Displays weight DN-119AT	8
2.3 Electrical characteristics of DN-129AT	9
2.3.1 Environmental conditions of DN-129AT	10
2.3.2 Dimensions of displays DN-129AT	11
2.3.3 Displays weight DN-129AT	11
2.4 Electrical characteristics of DN-189AT	12
2.4.1 Environmental conditions of DN-189AT	13
2.4.2 Dimensions of displays DN-189AT	14
2.4.3 Displays weight DN-189AT	14
<u>3. INSTALLATION</u>	16
3.1 Contents of the package	16
3.2 Initial set up	16
3.3 Position of connectors and buttons	17
3.4 Power supply	17
3.5 Input signal connection	18
3.5.1 Sensor Pt100. 3 wire connection.....	18
3.5.2 Sensor Pt100. 2 wire connection.....	18
3.5.3 Sensor thermocouple J, K o T.....	19
<u>4. OPERATION</u>	20
4.1 Initial Start UP.....	20
4.2 Power up test.....	20
4.3 Programming the parameters.....	20
4.3.1 Enter to modify parameters.....	20
4.3.2 Display errors.....	20
4.3.3 Parameters description.....	21
<u>5. SERIAL LINE OPTION</u>	23
5.1 Characteristics of the serial line	23
5.2 Wiring of serial line input.....	23
5.2.1 Wiring diagram between a DN-ATX and a PC using RS-232	24
5.2.2 Wiring diagram between a DN-ATX and a PC and a converter RS232/485	24
5.3 Modifying parameters of serial line option	25
5.3.1 Parameters description of serial line option.....	25
5.4 Communication Protocol.....	27
<u>6. RELAY OUTPUT OPTION AND COLOUR OPTION</u>	29
6.1 Characteristics of the relay output option	29
6.2 Wiring of relay output.....	29
6.3 Modifying parameters of relay output option	30
6.4 Parameters description of relay output option	30
6.5 Parameters description of colour option.....	32

DECLARATION OF CONFORMITY CE

1. INTRODUCTION.

The numerical displays for series **DN-109AT, DN-119AT, DN-129AT and DN-189AT (DN-1_9AT)** are industrial displays with analogue input for temperature displaying using PT-100, Thermocouple J, K or T. All the models are manufactured in versions of 3, 4 or 5 digits, with one or two display sides.

The large digit display size **DN-109AT of 57mm, DN-119AT of 100mm, DN-129AT of 250mm and DN-189AT of 180mm** with a legible distance from 30m to 120m, is one of the main characteristics.

The colour option, only available in some models, lets you select the digit colour between red, green and yellow.

All the equipment is provided completely calibrated, with the data stored in the memory non-volatile, eliminating the use of trimming potentiometers.

Available options:

- Colour option (**C**) Available to models DN-109 and DN-119.
- 2 Relay outputs. (**R**) Available to all models.
- Serial line. (**X**) To read the displayed value from a computer using a RS-232 or RS-485 connection. Available to all models.
- Protection degree IP65. (**e**) Available to models DN-109, DN-119 and DN-189
- Outdoor luminosity. (**h**). Available to models DN-119 and DN-189.
- Power supply 24VCC. Available to all models.

Available models from 3 to 5 digits, with 1 or 2 displaying sides.

Other models:

Within the visual display models **DN-1_9** there are manufactured other models for the following applications:

DN-1_9AP analog input for the control processes.

DN-1_9X control by serial line with Modbus, ASCII, Omron Host-Link and Siemens S7-200 protocols.

DN-1_9P control by digital inputs with BCD control, counter, tachometer, chronometer and binary.

DN-1_9ND control by DeviceNet network.

DN-1_9NE control by Ethernet. TCP/IP and Modbus/TCP.

DN-1_9NP control by Profibus-DP network.

DN-1_9NW control by Wifi. TCP/IP and Modbus/TCP.

DN-1_9TH Ambient temperature and relative humidity.

Option summary table

		IP65	Outdoor luminosity	2 Sides	Color Option
DN-109	3, 4 or 5 Digits	YES	NO	YES	YES
DN-119	3, 4 or 5 Digits	YES	YES	YES	NO
		YES	NO	YES	YES
DN-129	3, 4 or 5 Digits	NO	NO	YES	NO
DN-189	3, 4 or 5 Digits	YES	YES	YES	NO

1.1 Model reference structure

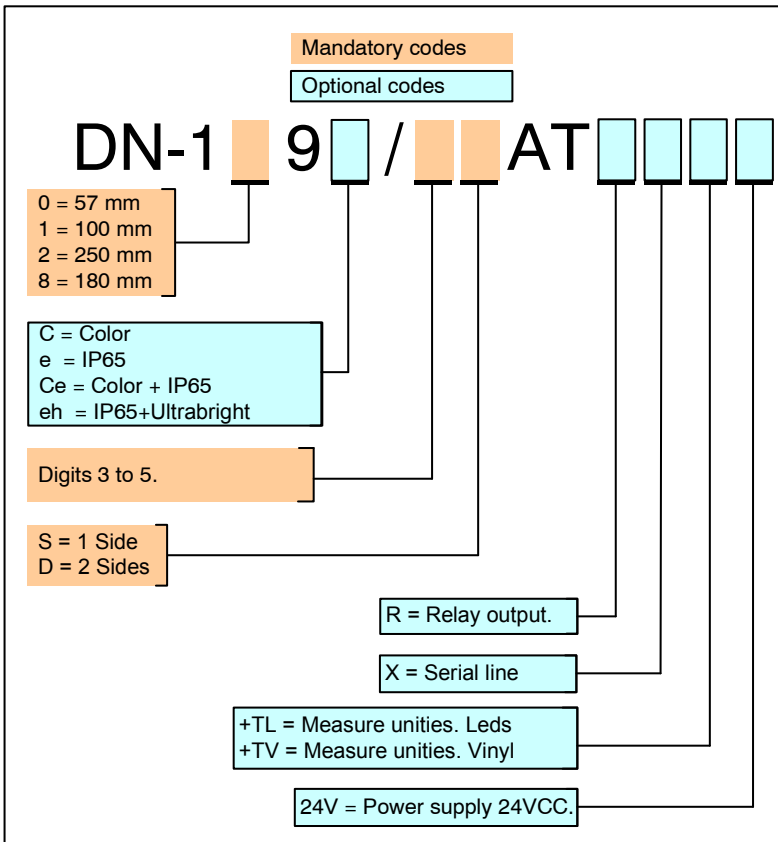

The model reference structure depends on installed options.

Some options are not available to all equipments. (Colour, IP65)

In this manual, we use **DN-109AT** when refer to **DN-109** with temperature input, independently of digits number, displaying sides and installed options.

In this manual, we use **DN-119AT** when refer to **DN-119** with temperature input, independently of digits number, displaying sides and installed options.

In this manual, we use **DN-129AT** when refer to **DN-129** with temperature input, independently of digits number, displaying sides and installed options.

In this manual, we use **DN-189AT** when refer to **DN-189** with temperature input, independently of digits number, displaying sides and installed options.

2. GENERAL SPECIFICATIONS

2.1 Electrical characteristics of DN-109AT.

Power supply	100VAc to 240VAC 50/60Hz
Consumption	22VA
Display	7 seg. 57mm + decimal point
	Red colour led.
Colour option	Colours Red, Green, Yellow.
Text option:	White Vinyl
Readable from	30 m.
Parameters memory	Eeprom

Input signal

Configuration..... Differential asymmetrical.

Digits	Resolu.	Pt100 °C	TC "J" °C	TC "K" °C	TC "T" °C
3	0.1°	-19.9 / +99.9	-19.9 / +99.9	-19.9 / +99.9	-19.9 / +99.9
3	1°	-199 / +800	-50 / +760	-50 / +999	-160 / +400
4	0.1°	-199.9 / +400.0	-50.0 / +760.0	-50.0 / +999.9	-160.0 / +400.0
4	1°	-199 / +800	-50 / +760	-50 / +1370	-160 / +400
5	0.1°	-200.0 / +400.0	-50.0 / +760.0	-50.0 / +1370.0	-160.0 / +400.0
5	1°	-200 / +800	-50 / +760	-50 / +1370	-160 / +400

Digits	Resolu.	Pt100 °F	TC "J" °F	TC "K" °F	TC "T" °F
3	0.1°	-19.9 / +99.9	-19.9 / +99.9	-19.9 / +99.9	-19.9 / +99.9
3	1°	-199 / +999	-58 / +999	-58 / +999	-199 / +752
4	0.1°	-199.9 / +752.0	-58.0 / +999.9	-58.0 / +999.9	-199.9 / +752.0
4	1°	-328 / +1472	-58 / +1400	-58 / +2498	-256 / +752
5	0.1°	-328.0 / +752.0	-58.0 / +1400.0	-58.0 / +2498.0	-256.0 / +752.0
5	1°	-328 / +1472	-58 / +1400	-58 / +2498	-256 / +752

Accuracy to 22° ±5°C

Pt100 Resolution 0,1°C.....	±0.1 of reading +0.3°C
Pt100 Resolution 1°C.....	±0.1 of reading +1°C
Pt100 Resolution 0,1°F.....	±0.1 of reading +0.5°F
Pt100 Resolution 1°F.....	±0.1 of reading +1°F
TC: J, K, T Resolution 0,1°C.....	±0.4% of reading +0.6°C
TC: J, K, T Resolution 0,1°F.....	±0.4% of reading +1°F
TC: J, K, T Resolution 1°C.....	±0.4% of reading +1°C
TC: J, K, T Resolution 1°F.....	±0.4% of reading +2°F
Temperature coefficient.....	100 ppm/°C
Warm up time.....	5 minutes

Conversion method

Technique.....	Sigma-Delta
Resolution.....	16 bits
Rate.....	25/ s

Display

Over-range 3 digits displays.....	-OE/ OuE
Over-range 4 and 5 digits displays.....	-OuE / OuE
Wire open.....	E1

2.1.1 Environmental conditions of displays DN-109AT.

Operating temperature 0° to 50° C
Storage temperature -10° to 60°C
Relative humidity 5 a 95% non condensation.
Maximum environmental lighting 1000 lux
DN-109AT Protection degree IP41.
DN-109eAT Protection degree IP65.

Characteristics summary table

n = Number of digits	n = Number of digits	Protecti on	Relay outputs	Serial line	Number of sides
DN-109/nSAT	DN-109C/nSAT	IP-41	NO	NO	1
DN-109/nDAT	DN-109C/nDAT	IP-41	NO	NO	2
DN-109/nSATX	DN-109C/nSATX	IP-41	NO	SI	1
DN-109/nDATX	DN-109C/nDATX	IP-41	NO	SI	2
DN-109/nSATR	DN-109C/nSATR	IP-41	SI	NO	1
DN-109/nDATR	DN-109C/nDATR	IP-41	SI	NO	2
DN-109/nSATXR	DN-109C/nSATXR	IP-41	SI	SI	1
DN-109/nDATXR	DN-109C/nDATXR	IP-41	SI	SI	2
DN-109e/nSAT	DN-109Ce/nSAT	IP-65	NO	NO	1
DN-109e/nDAT	DN-109Ce/nDAT	IP-65	NO	NO	2
DN-109e/nSATX	DN-109Ce/nSATX	IP-65	NO	SI	1
DN-109e/nDATX	DN-109Ce/nDATX	IP-65	NO	SI	2
DN-109e/nSATR	DN-109Ce/nSATR	IP-65	SI	NO	1
DN-109e/nDATR	DN-109Ce/nDATR	IP-65	SI	NO	2
DN-109e/nSATXR	DN-109Ce/nSATXR	IP-65	SI	SI	1
DN-109e/nDATXR	DN-109Ce/nDATXR	IP-65	SI	SI	2

Available models from 3 to 5 digits.

Option colour available on all models DN-109/AT

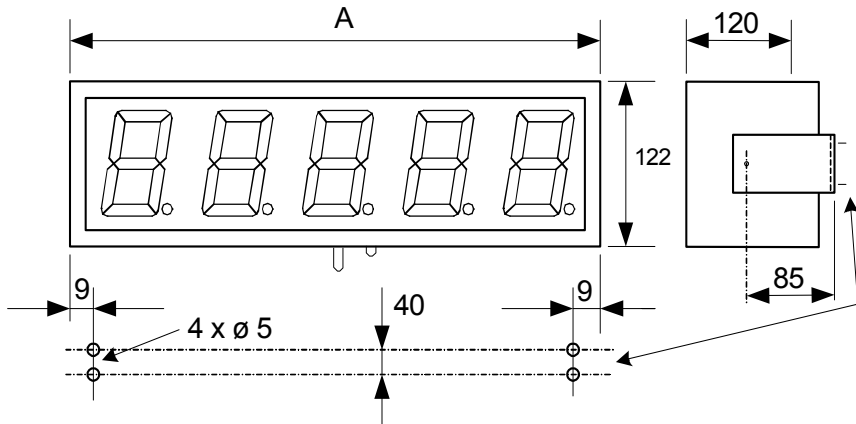
2.1.2 Dimensions of displays DN-109AT.

A according to digit's number

n (digit's num.)	3	4	5
DN-109(C)(e)/SnAT	210	288	288
DN-109(C)(e)/SnAT+T	306	384	384
DN-109(C)(e)/DnAT	288	288	288
DN-109(C)(e)/DnAT+T	306	384	384

C= Colour e= IP65

2.1.3 Displays weight DN-109AT.

n (digit's num.)	3	4	5
DN-109(C)(e)/SnAT	2 kg	2 kg	3 kg
DN-109(C)(e)/SnAT+T	3 kg	3 kg	3 kg
DN-109(C)(e)/DnAT	----	2 kg	3 kg
DN-109(C)(e)/DnAT+T	3 kg	3 kg	3 kg

C= Colour e= IP65

2.2 Electrical characteristics of DN-119AT.

Power supply	100VAc to 240VAC 50/60Hz
Consumption	26VA
Display	7 seg. 100mm + decimal point
.....	Red colour led.
Colour option	Colours Red, Green, Yellow.
Text option:	White Vinyl
Readable from	50 m.
Parameters memory	Eeprom

Input signal

Configuration

Differential asymmetrical.

Digits	Resolu.	Pt100 °C	TC "J" °C	TC "K" °C	TC "T" °C
3	0.1°	-19.9 / +99.9	-19.9 / +99.9	-19.9 / +99.9	-19.9 / +99.9
3	1°	-199 / +800	-50 / +760	-50 / +999	-160 / +400
4	0.1°	-199.9 / +400.0	-50.0 / +760.0	-50.0 / +999.9	-160.0 / +400.0
4	1°	-199 / +800	-50 / +760	-50 / +1370	-160 / +400
5	0.1°	-200.0 / +400.0	-50.0 / +760.0	-50.0 / +1370.0	-160.0 / +400.0
5	1°	-200 / +800	-50 / +760	-50 / +1370	-160 / +400

Digits	Resolu.	Pt100 °F	TC "J" °F	TC "K" °F	TC "T" °F
3	0.1°	-19.9 / +99.9	-19.9 / +99.9	-19.9 / +99.9	-19.9 / +99.9
3	1°	-199 / +999	-58 / +999	-58 / +999	-199 / +752
4	0.1°	-199.9 / +752.0	-58.0 / +999.9	-58.0 / +999.9	-199.9 / +752.0
4	1°	-328 / +1472	-58 / +1400	-58 / +2498	-256 / +752
5	0.1°	-328.0 / +752.0	-58.0 / +1400.0	-58.0 / +2498.0	-256.0 / +752.0
5	1°	-328 / +1472	-58 / +1400	-58 / +2498	-256 / +752

Accuracy to 22° ±5°C

Pt100 Resolution 0,1°C	±0.1 of reading +0.3°C
Pt100 Resolution 1°C	±0.1 of reading +1°C
Pt100 Resolution 0,1°F	±0.1 of reading +0.5°F
Pt100 Resolution 1°F	±0.1 of reading +1°F
TC: J, K, T Resolution 0,1°C	±0.4% of reading +0.6°C
TC: J, K, T Resolution 0,1°F	±0.4% of reading +1°F
TC: J, K, T Resolution 1°C	±0.4% of reading +1°C
TC: J, K, T Resolution 1°F	±0.4% of reading +2°F
Temperature coefficient	100 ppm/ °C
Warm up time	5 minutes

Conversion method

Technique	Sigma-Delta
Resolution	16 bits
Rate	25/ s

Display

Over-range 3 digits displays	-OE/ OuE
Over-range 4 and 5 digits displays	-OuE / OuE
Wire open	E1

2.2.1 Environmental conditions of displays DN-119AT.

Operating temperature 0° to 50° C
Storage temperature -10° to 60°C
Relative humidity 5 a 95% non condensation.

DN-119AT and DN-119eAT Maximum environmental lighting 1000 lux
DN-119AT Protection degree IP41.
DN-119ehAT Maximum environmental lighting Outdoor
DN-119eAT and DN-119ehAT Protection degree IP65.

Characteristics summary table

n = Number of digits	n = Number of digits	n = Number of digits	Protecti on	Relay outputs	Serial line	Number of sides
DN-119/nSAT	DN-119C/nSAT	-----	IP-41	NO	NO	1
DN-119/nDAT	DN-119C/nDAT	-----	IP-41	NO	NO	2
DN-119/nSATX	DN-119C/nSATX	-----	IP-41	NO	SI	1
DN-119/nDATX	DN-119C/nDATX	-----	IP-41	NO	SI	2
DN-119/nSATR	DN-119C/nSATR	-----	IP-41	SI	NO	1
DN-119/nDATR	DN-119C/nDATR	-----	IP-41	SI	NO	2
DN-119/nSATXR	DN-119C/nSATXR	-----	IP-41	SI	SI	1
DN-119/nDATXR	DN-119C/nDATXR	-----	IP-41	SI	SI	2
DN-119e/nSAT	DN-119Ce/nSAT	DN-119eh/nSAT	IP-65	NO	NO	1
DN-119e/nDAT	DN-119Ce/nDAT	DN-119eh/nDAT	IP-65	NO	NO	2
DN-119e/nSATX	DN-119Ce/nSATX	DN-119eh/nSATX	IP-65	NO	SI	1
DN-119e/nDATX	DN-119Ce/nDATX	DN-119eh/nDATX	IP-65	NO	SI	2
DN-119e/nSATR	DN-119Ce/nSATR	DN-119eh/nSATR	IP-65	SI	NO	1
DN-119e/nDATR	DN-119Ce/nDATR	DN-119eh/nDATR	IP-65	SI	NO	2
DN-119e/nSATXR	DN-119Ce/nSATXR	DN-119eh/nSATXR	IP-65	SI	SI	1
DN-119e/nDATXR	DN-119Ce/nDATXR	DN-119eh/nDATXR	IP-65	SI	SI	2

Available models from 3 to 5 digits.

Option colour available on all models DN-119/AT

2.2.2 Dimensions of displays DN-119AT.

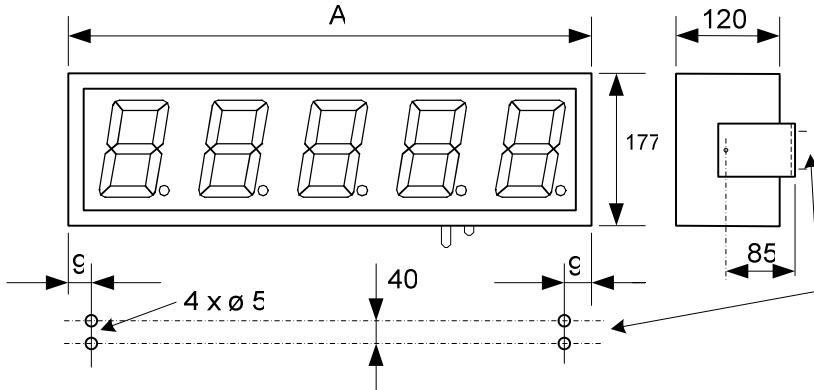

A according to digit's number

n (digit's num.)	3	4	5
DN-119(C)(e)(h)/SnAT	324	414	504
DN-119(C)(e)(h)/SnAT+T	504	594	684
DN-119(C)(e)(h)/DnAT	324	414	504
DN-119(C)(e)(h)/DnAT+T	504	594	684

C= Colour e=IP65 h=outdoor luminosity

2.2.3 Displays weight DN-119AT.

n (digit's num.)	3	4	5
DN-119(C)(e)(h)/SnAT	4 kg	4 kg	4,5 kg
DN-119(C)(e)(h)/SnAT+T	4,5 kg	4,5 kg	5 kg
DN-119(C)(e)(h)/DnAT	4 kg	4,5 kg	4,5 kg
DN-119(C)(e)(h)/DnAT+T	4,5 kg	4,5 kg	5 kg

C= Colour e=IP65 h=outdoor luminosity

2.3 Electrical characteristics of DN-129AT.

Power supply	100VAc to 240VAC 50/60Hz
Consumption	40VA
Display	7 seg. 250mm + decimal point
.....	Red colour led.
Text option:	White Vinyl
Readable from	120 m.
Parameters memory	Eeprom

Input signal

Configuration..... Differential asymmetrical.

Digits	Resolu.	Pt100 °C	TC "J" °C	TC "K" °C	TC "T" °C
3	0.1°	-19.9 / +99.9	-19.9 / +99.9	-19.9 / +99.9	-19.9 / +99.9
3	1°	-199 / +800	-50 / +760	-50 / +999	-160 / +400
4	0.1°	-199.9 / +400.0	-50.0 / +760.0	-50.0 / +999.9	-160.0 / +400.0
4	1°	-199 / +800	-50 / +760	-50 / +1370	-160 / +400
5	0.1°	-200.0 / +400.0	-50.0 / +760.0	-50.0 / +1370.0	-160.0 / +400.0
5	1°	-200 / +800	-50 / +760	-50 / +1370	-160 / +400

Digits	Resolu.	Pt100 °F	TC "J" °F	TC "K" °F	TC "T" °F
3	0.1°	-19.9 / +99.9	-19.9 / +99.9	-19.9 / +99.9	-19.9 / +99.9
3	1°	-199 / +999	-58 / +999	-58 / +999	-199 / +752
4	0.1°	-199.9 / +752.0	-58.0 / +999.9	-58.0 / +999.9	-199.9 / +752.0
4	1°	-328 / +1472	-58 / +1400	-58 / +2498	-256 / +752
5	0.1°	-328.0 / +752.0	-58.0 / +1400.0	-58.0 / +2498.0	-256.0 / +752.0
5	1°	-328 / +1472	-58 / +1400	-58 / +2498	-256 / +752

Accuracy to 22° ±5°C

Pt100 Resolution 0,1°C	±0.1 of reading +0.3°C
Pt100 Resolution 1°C	±0.1 of reading +1°C
Pt100 Resolution 0,1°F	±0.1 of reading +0.5°F
Pt100 Resolution 1°F	±0.1 of reading +1°F
TC: J, K, T Resolution 0,1°C	±0.4% of reading +0.6°C
TC: J, K, T Resolution 0,1°F	±0.4% of reading +1°F
TC: J, K, T Resolution 1°C	±0.4% of reading +1°C
TC: J, K, T Resolution 1°F	±0.4% of reading +2°F
Temperature coefficient	100 ppm/ °C
Warm up time	5 minutes

Conversion method

Technique	Sigma-Delta
Resolution	16 bits
Rate	25/ s

Display

Over-range 3 digits displays	-OE/ OuE
Over-range 4 and 5 digits displays	-OuE / OuE
Wire open	E1

2.3.1 Environmental conditions of displays DN-129AT.

Operating temperature 0° to 50° C
Storage temperature -10° to 60°C
Relative humidity 5 a 95% non condensation.
Maximum environmental lighting 2000 lux
Protection degree IP41.

Characteristics summary table

n = Number of digits	Protecti on	Relay outputs	Serial line	Number of sides
DN-129/nSAT	IP-41	NO	NO	1
DN-129/nDAT	IP-41	NO	NO	2
DN-129/nSATX	IP-41	NO	YES	1
DN-129/nDATX	IP-41	NO	YES	2
DN-129/nSATR	IP-41	YES	NO	1
DN-129/nDATR	IP-41	YES	NO	2
DN-129/nSATXR	IP-41	YES	YES	1
DN-129/nDATXR	IP-41	YES	YES	2

Available models from 3 to 5 digits.

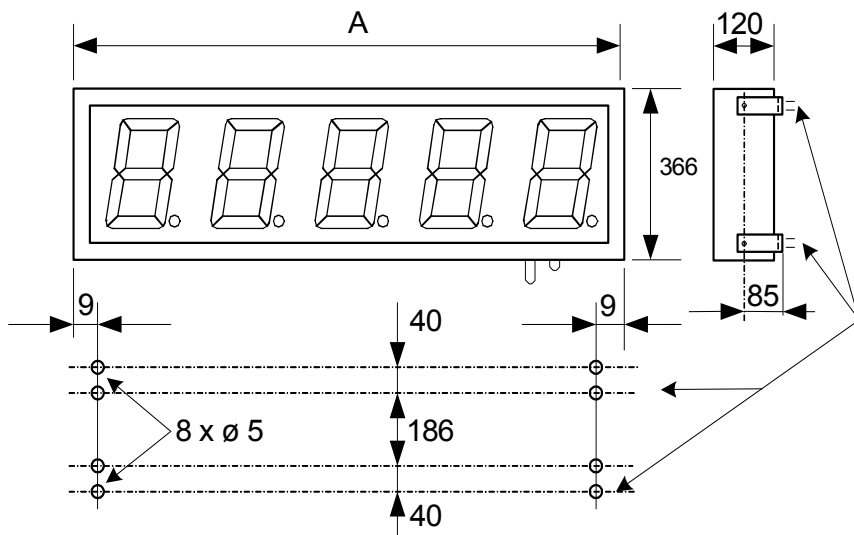
2.3.2 Dimensions of displays DN-129AT.

A according to digit's number

n (digit's num.)	3	4	5
DN-129/SnAT	750	985	1220
DN-129/SnAT+T	1220	1455	1690
DN-129/DnAT	750	985	1220
DN-129/DnAT+T	1220	1455	1690

2.3.3 Displays weight DN-129AT.

n (Chiffres)	3	4	5
DN-129/SnAT	8,5 kg	10 kg	11,5 kg
DN-129/SnAT+T	11,5 kg	13 kg	15 kg
DN-129/DnAT	10 kg	12,5 kg	14,5 kg
DN-129/DnAT+T	14 kg	16 kg	18,5 kg

2.4 Electrical characteristics of DN-189AT.

Power supply	100VAc to 240VAC 50/60Hz
Consumption	26VA
Display	7 seg. 180mm + decimal point
	Red colour led.
Text option:	White Vinyl
Readable from	90 m.
Parameters memory	Eeprom

Input signal

Configuration..... Differential asymmetrical.

Digits	Resolu.	Pt100 °C	TC "J" °C	TC "K" °C	TC "T" °C
3	0.1°	-19.9 / +99.9	-19.9 / +99.9	-19.9 / +99.9	-19.9 / +99.9
3	1°	-199 / +800	-50 / +760	-50 / +999	-160 / +400
4	0.1°	-199.9 / +400.0	-50.0 / +760.0	-50.0 / +999.9	-160.0 / +400.0
4	1°	-199 / +800	-50 / +760	-50 / +1370	-160 / +400
5	0.1°	-200.0 / +400.0	-50.0 / +760.0	-50.0 / +1370.0	-160.0 / +400.0
5	1°	-200 / +800	-50 / +760	-50 / +1370	-160 / +400

Digits	Resolu.	Pt100 °F	TC "J" °F	TC "K" °F	TC "T" °F
3	0.1°	-19.9 / +99.9	-19.9 / +99.9	-19.9 / +99.9	-19.9 / +99.9
3	1°	-199 / +999	-58 / +999	-58 / +999	-199 / +752
4	0.1°	-199.9 / +752.0	-58.0 / +999.9	-58.0 / +999.9	-199.9 / +752.0
4	1°	-328 / +1472	-58 / +1400	-58 / +2498	-256 / +752
5	0.1°	-328.0 / +752.0	-58.0 / +1400.0	-58.0 / +2498.0	-256.0 / +752.0
5	1°	-328 / +1472	-58 / +1400	-58 / +2498	-256 / +752

Accuracy to 22° ±5°C

Pt100 Resolution 0,1°C	±0.1 of reading +0.3°C
Pt100 Resolution 1°C	±0.1 of reading +1°C
Pt100 Resolution 0,1°F	±0.1 of reading +0.5°F
Pt100 Resolution 1°F	±0.1 of reading +1°F
TC: J, K, T Resolution 0,1°C	±0.4% of reading +0.6°C
TC: J, K, T Resolution 0,1°F	±0.4% of reading +1°F
TC: J, K, T Resolution 1°C	±0.4% of reading +1°C
TC: J, K, T Resolution 1°F	±0.4% of reading +2°F
Temperature coefficient	100 ppm/ °C
Warm up time	5 minutes

Conversion method

Technique	Sigma-Delta
Resolution	16 bits
Rate	25/ s

Display

Over-range 3 digits displays	-OE/ OuE
Over-range 4 and 5 digits displays	-OuE / OuE
Wire open	E1

2.4.1 Environmental conditions of displays DN-189AT.

Operating temperature 0° to 50° C
Storage temperature -10° to 60°C
Relative humidity 5 a 95% non condensation.
DN-189AT and DN-189eAT Maximum environmental lighting 2000 lux
DN-189AT Protection degree IP41.
DN-189ehAT Maximum environmental lighting Outdoor
DN-189eAT and DN-189ehAT Protection degree IP65.

Characteristics summary table

n = Number of digits	n = Number of digits	Protecti on	Relay outputs	Serial line	Number of sides
DN-189/nSAT	-----	IP-41	NO	NO	1
DN-189/nDAT	-----	IP-41	NO	NO	2
DN-189/nSATX	-----	IP-41	NO	SI	1
DN-189/nDATX	-----	IP-41	NO	SI	2
DN-189/nSATR	-----	IP-41	SI	NO	1
DN-189/nDATR	-----	IP-41	SI	NO	2
DN-189/nSATXR	-----	IP-41	SI	SI	1
DN-189/nDATXR	-----	IP-41	SI	SI	2
DN-189e/nSAT	DN-189eh/nSAT	IP-65	NO	NO	1
DN-189e/nDAT	DN-189eh/nDAT	IP-65	NO	NO	2
DN-189e/nSATX	DN-189eh/nSATX	IP-65	NO	SI	1
DN-189e/nDATX	DN-189eh/nDATX	IP-65	NO	SI	2
DN-189e/nSATR	DN-189eh/nSATR	IP-65	SI	NO	1
DN-189e/nDATR	DN-189eh/nDATR	IP-65	SI	NO	2
DN-189e/nSATXR	DN-189eh/nSATXR	IP-65	SI	SI	1
DN-189e/nDATXR	DN-189eh/nDATXR	IP-65	SI	SI	2

h= outdoor luminosity

Available models from 3 to 5 digits.

2.4.2 Dimensions of displays DN-189AT.

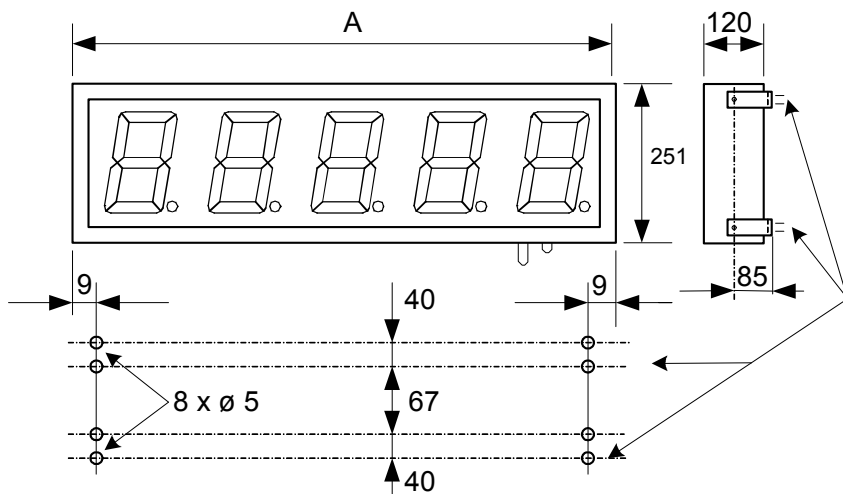

A according to digit's number

n (digit's num.)	3	4	5
DN-189(e)(h)/SnAT	500	660	820
DN-189(e)(h)/SnAT+T	820	980	1140
DN-189(e)(h)/DnAT	500	660	820
DN-189(e)(h)/DnAT+T	820	980	1140

e=IP65 h=outdoor luminosity

2.4.3 Displays weight DN-189AT.

n (digit's num.)	3	4	5
DN-189(e)(h)/SnAT	5 kg	6 kg	7,5 kg
DN-189(e)(h)/SnAT+T	7 kg	8 kg	9 kg
DN-189(e)(h)/DnAT	6 kg	7,5kg	8,5 kg
DN-189(e)(h)/DnAT+T	8 kg	9,5 kg	10,5 kg

e=IP65 h=outdoor luminosity

3. INSTALLATION

There are some considerations to take into account before installing **DN-1_9AT**.

The displays must neither be fixed to places close to vibration nor to places which exceed the limits of temperature and humidity specified in the display characteristics.

The protection degree of **DN-1_9AT** displays is IP41, which means that they are protected against the penetration of solid objects of more than 1mm diameter and against the vertical falling of drops. The protection degree of **DN-1_9e/AT** and **DN-1_9eh/AT** is IP65, which means that they are protected against dust and water jet.

The **DN-1_9AT** displays, must not be installed where the lighting level is higher than 1000 lux. They must be protected against direct sunlight.

The **DN-1_9eh/AT** may work on direct sunlight.

They must stay away from high frequency generators, which are frequent in soldering equipment U/F converters for motors.

**Displays DN-1_9eAT and DN-1_9AT:
To obtain the IP65 protection you must use the water resistant hood supplied with the display**

3.1. Contents of the package.

Before proceeding to the installation of the equipment, we recommend that you identify all the material which has been received. In the box, you will find the following material:

- Operation manual
- Visual Display Unit
- 2 Mounting brackets for the models DN-109/AT and DN-119/AT
- 4 Mounting brackets for the model DN-129/AT and DN-189/AT
- One bag containing: 1 Power lead connector, 1 connector for analogue input, 2 (4) knobs, 2(4) nylon washers.
- Equipment with IP65 option: 1 analog input connector hood.

3.2. Initial Setup.

Before connecting the display for the first time, you must setup the parameters depending on what output values you want. Follow steps on section 4.3 and the next ones to setup the parameters.

3.3 Position of connectors and buttons

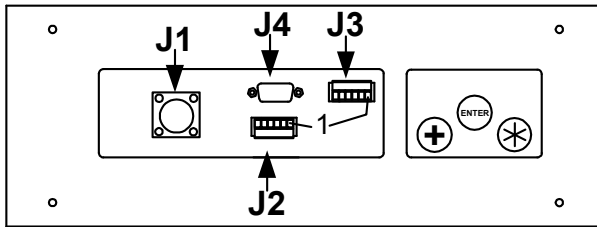

Fig. 3.1 Position of connectors and buttons

The signal connectors are situated in the lower part of the unit (fig. 3.1). Depending on the installed options, the unit will possess various types of connectors.

Connector **J2**: Analogue inputs.

Connector **J3**: Relay output. Units with the **R** option.

Connector **J4**: Serial line. Equipment with the **X** option.

The J1 power lead connector is situated in the lower part of the unit, except in DN-109/3AT models where this is in the upper part of the unit.

The buttons for configuration of the equipment are located in the lower part. They are identified with the symbols +, * and the text «ENTER».

3.4 Power supply.

Power supply must be from **100VAC to 240VAC, 50/60 Hz** or 24VDC optionally.

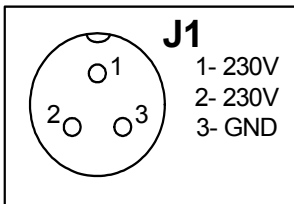

Fig. 3.2 Power supply 230VAC

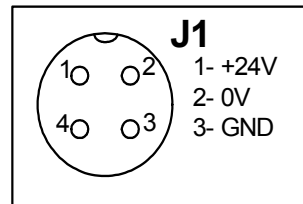

Fig. 3.3 Power supply 24V CC

The section of power supply conductors is in keeping with the consumption. The earth conductor will be minimum 1,5mm².

The supply connector is a three-contact type and is located at the bottom of the unit. The connection must be made according to figure 3.2 for power supply of 230VAC and according to figure 3.3 for power supply of 24VCC.

3.5 Input signal connection.

In all the mountings, the connection of the inputs must be done using braided and insulated cable. The screen must only be connected to terminal 1 of the input connector.

3.5.1 Sensor Pt100. 3 wires connection.

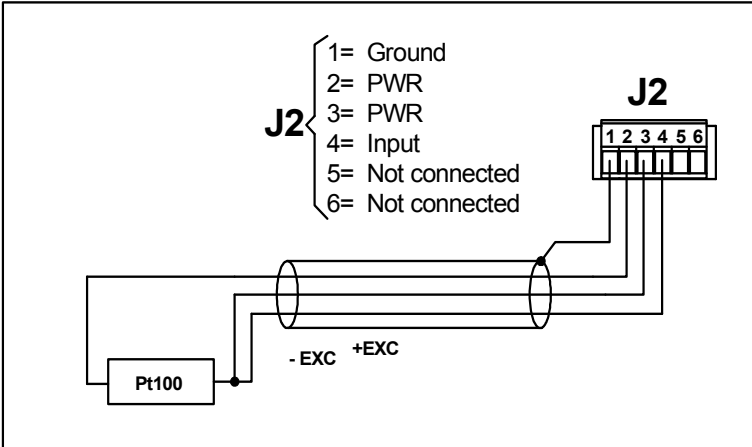

Position of **J2** connector on page 13

3.5.2 Sensor Pt100. 2 wires connection.

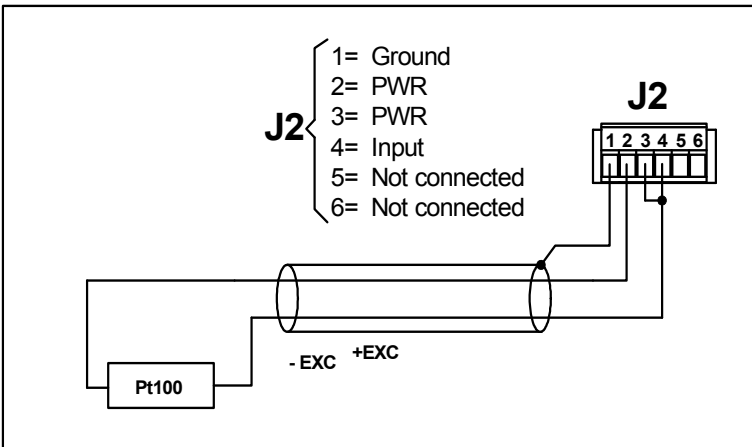

Position of **J2** connector on page 13

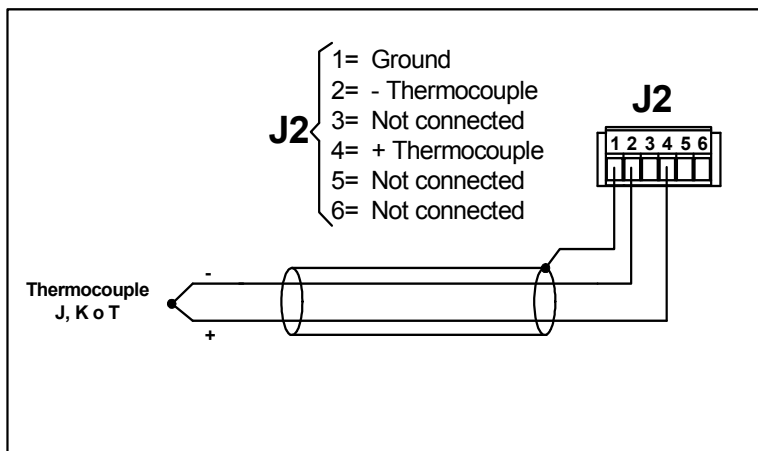
3.5.3 Sensor thermocouple J, K o T.

Position of **J2** connector on page 13

4. OPERATION

4.1 Initial Start UP

Before connecting the display for the first time, you must setup the parameters depending on what output values you want. Follow steps on section 4.3 and the next ones to setup the parameters.

Before connecting the display to the network, it must be checked that all connections have been set properly and that the display have been firmly placed.

4.2 Power up test

Every time the display is connected to the supply network, there is an initial reset, which check all the segments of the display. The test consist on the sequential lightening of all digits with value "8", all digits with value "0" and at last of all decimal points.

On the next step the version code is shown and the equipment is ready to work.

4.3 Programming the parameters

Before using the display the parameters listed below must be configured:

The type of sensor used: Pt100, Thermocouple J, K o T.

Scale used: Celsius or Fahrenheit.

Resolution: 1 Degree or 0.1 Degree.

Offset: To modify the display value with a fixed value. For 1 degree resolution the range is $\pm 99^\circ$. For 0.1 degree resolution the range is $\pm 9.9^\circ$

4.3.1 Enter to modify parameters.

To enter into the sequence for modifying parameters, one must press and hold the key * for three seconds. After this time, the word «Pro» will be displayed. Pressing the ENTER key, one accesses the configuration menu for input type, display value and the installed options. After configuring each one of the menus, the RUN mode is returned to for normal operation of the display.

The function of each key is the following:



Enter to modify parameters. Advance through the menu selections. Advance through the selection of digits.



Increase the value of one digit. Upon reaching 9, you can go on (or only back to 0, depending on the function of the digit).



Validate the value of a field. Change the parameter.

4.3.2 Display errors.

If an error is detected during the operation, the following codes are displayed:

E1: Wire open.

-OE / OuE: Overrun on 3 digits displays.

-OuE / OuE: Overrun on 4 or 5 digit displays.

4.3.3 Parameters description

The sequence for modifying parameters has been entered.
Press ENTER to continue.

Menu of sensor temperature. Upon pressing ENTER, the last type of input selected is displayed.

Sensor Pt100 selected. Press * to select thermocouple J sensor. Press ENTER to validate the value and to access the next parameter.

Thermocouple J sensor selected. Press * to select thermocouple K sensor. Press ENTER to validate the value and to access the next parameter.

Thermocouple K sensor selected. Press * to select thermocouple T sensor. Press ENTER to validate the value and to access the next parameter.

Thermocouple T sensor selected. Press * to select Pt100 sensor. Press ENTER to validate the value and to access the next parameter.

Celsius scale selected. Press * to select Fahrenheit scale. Press ENTER to validate the value and to access the next parameter.

Fahrenheit scale selected. Press * to select Celsius scale. Press ENTER to validate the value and to access the next parameter.

Resolution of 1 degree selected. Press * to select resolution of 0.1 degree
Press ENTER to validate the value and to access the next parameter.

Resolution of 0.1 degree selected. Press * to select resolution of 1 degree
Press ENTER to validate the value and to access the next parameter.

Offset value. After 2 seconds the last programmed value is displayed and modification is permitted. Upon pressing ENTER the value is validated and the programming of the parameters is finalized.

Offset value. Use the increase and displacement keys to modify the value. Upon reaching 9, it goes back to 0. The highest weight digit permits programming of the sign - (negative value)

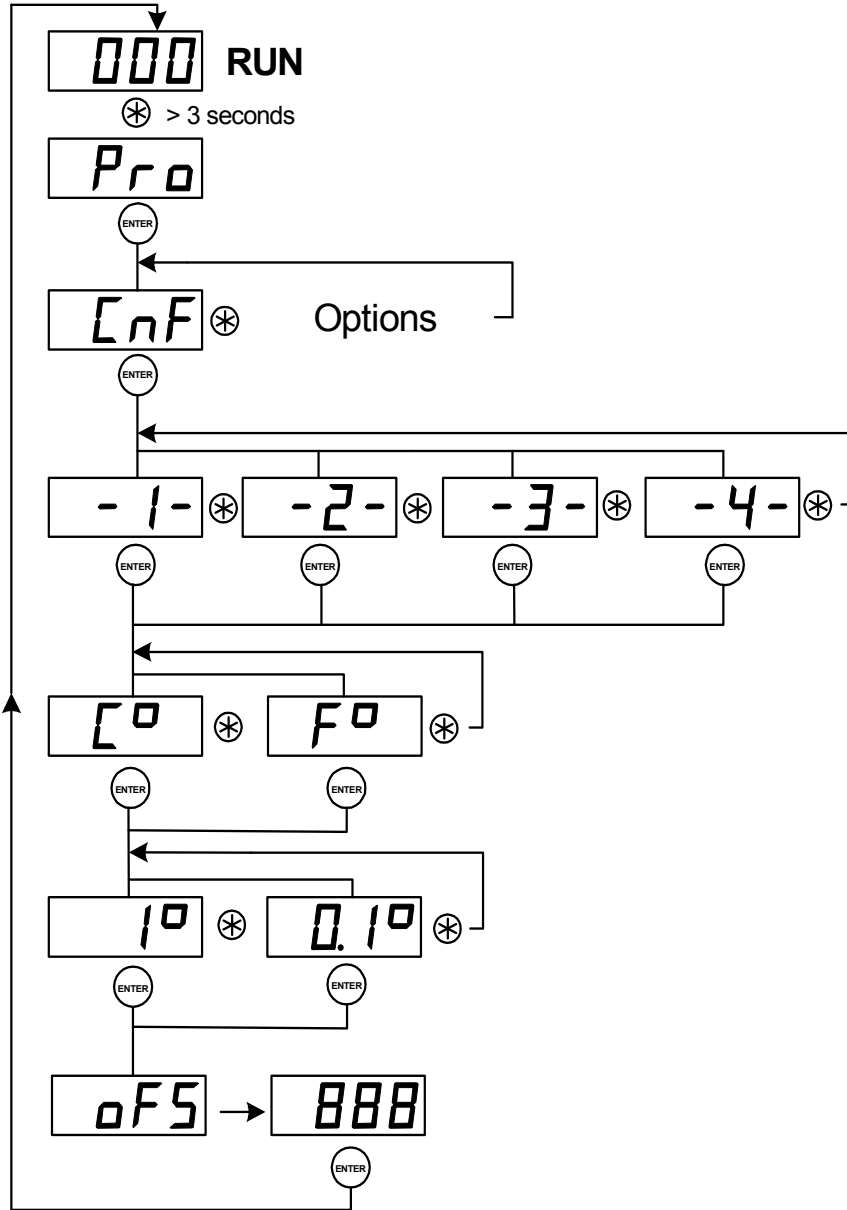

DISPLAYS WITH COLOUR OPTION:
To program the display colour see the paragraph: Relay option on Chapter 6.

5. SERIAL LINE OPTION

The displays which possess the serial line option (**DN-1_9ATX**. See Section 1.1) may communicate with a computer in order to carry out the parameter programming (through the DNWIN software) or in order to send the information of the analogue input to the computer.

All the units with the serial line input option have two kinds of connections: RS-232C and RS-485.

5.1 Characteristics of the serial line.

Only one DB9 Connector for RS-232C and RS-485.

Baud rate: 9600 and 19200.

Parity control: Even , odd, no parity.

Data bits: 7 or 8.

Stop bits: 1 or 2.

5.2 Wiring of serial line input.

DN-1_9ATX series displays accept two types of serial input RS-232 and RS-485. The same connector is used for both inputs (type DB-9), and is located at the bottom of the equipment.

The selection of the series line type is done programming the parameters.

The wiring diagram is shown below:

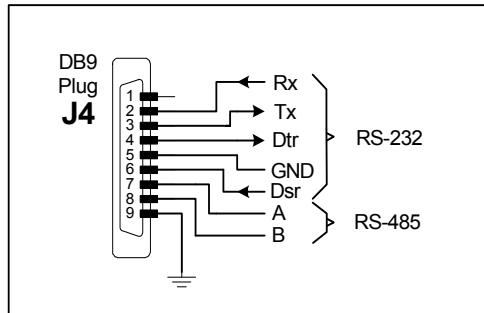

CONNECTOR SERIES DN-1_9ATX

Position of **J4** connector on page 13

5.2.1 Wiring diagram between a DN-1_9ATX and a PC using RS-232.

In a RS-232 connection the line length must not surpass **5m**. It is important to use shield cable and to connect the screen to pin 9 in the connector DB9. The network must avoid the proximity with high power lines.

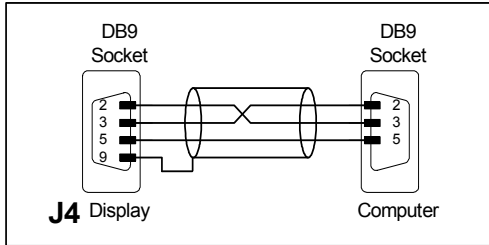

RS-232 connection between a DN-1_9ATX and a PC

Position of **J4** connector on page 13.

The connector type (plug or socket) correspond to the cable.

5.2.2 RS-485 Connection between a DN-1_9ATX, and PC using a RS-232/422/485 Afeisa converter.

In a RS-485 connection the line length must not surpass 1000m, without amplifiers. It is necessary to use shielded pair cable and to connect the screen to pin 9 in the connector DB9. The network must avoid the proximity with high power lines. Branches from the network to the displays must be as short as possible. Resistors of the end of the line of 120 Ohm have to be set in order to assure a good working order of the network.

In connector DB9 there is place enough to set the resistance together with the connection.

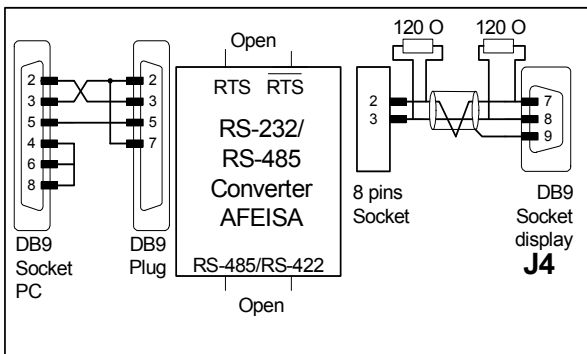

Position of **J4** connector on page 13.

The connector type (plug or socket) correspond to the cable.

5.3 Modifying parameters of serial line option.

In order to configure the parameters, one must access the parameter modifying menu according to how it is detailed in Section 4.3.2. The parameters of the serial line are accessed from the LSE symbol.

5.3.1 Parameters description of serial line option

The symbol consists of the letters 'LSE' in a bold, monospaced font, enclosed within a rectangular border.

Selection menu for the serial line. Upon pressing ENTER the menu is accessed.

The symbol consists of the letters 'Add' in a bold, monospaced font, enclosed within a rectangular border.

Value of the display address on the network. After 2 seconds, the last value programmed is displayed and is permitted to be modified. Upon pressing ENTER the value is validated and the next parameter is accessed. The range of values is from 00 to 99.

The symbol consists of the letters 'bAU' in a bold, monospaced font, enclosed within a rectangular border.

Baud rate. After 2 seconds, the last value programmed is displayed and permitted to be modified. Upon pressing ENTER the value is validated and the next parameter is accessed. The range of values is 9600(96) and 19200(192).

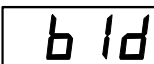
The symbol consists of the letters 'bId' in a bold, monospaced font, enclosed within a rectangular border.

Data bits. After 2 seconds, the last value programmed is displayed and permitted to be modified. Upon pressing ENTER the value is validated and the next parameter is accessed. The range of values is 7 and 8.

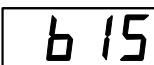
The symbol consists of the letters 'bIS' in a bold, monospaced font, enclosed within a rectangular border.

Stop bits. After 2 seconds, the last value programmed is displayed and permitted to be modified. Upon pressing ENTER the value is validated and the next parameter is accessed. The range of values is 1 and 2

The symbol consists of the letters 'PAR' in a bold, monospaced font, enclosed within a rectangular border.

Parity. After 2 seconds, the last value programmed is displayed and permitted to be modified. Upon pressing ENTER the value is validated and the next parameter is accessed. The range of Even Parity (PrP), Odd Parity (PrI) and Non Parity (Prn)

The symbol consists of the letters 'LPL' in a bold, monospaced font, enclosed within a rectangular border.

Type of serial line. After 2 seconds, the last value programmed is displayed and permitted to be modified. Upon pressing ENTER the value is validated and the next parameter is accessed. The range of values is RS-232C(232) and RS-485(485).

Serial line option

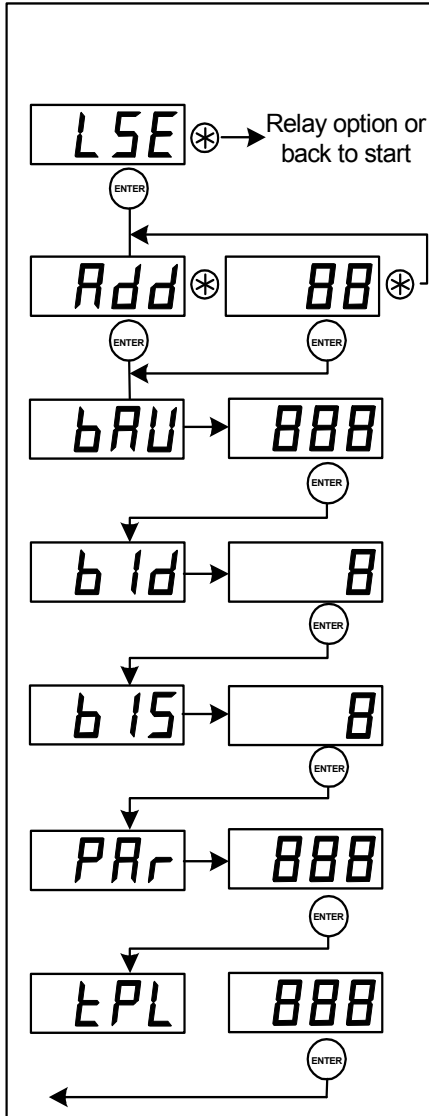

5.4 Communication protocol.

The communication protocol used is based in ASCII characters. The display unit always works in slave mode, which is to say that it waits to receive a correct raster (Query) in order to be able to return the raster with the data requested (Reply).

All the transmission blocks have the same structure: Header, network address, data and end of block.

Query block:

Block header: Always is the character @. Hexadecimal code 41h.

Network address: Comprised of 2 characters in ASCII code hexadecimal. The first character is the upper part of the address. The second character is the lower part of the address.

Data: This could be the query code or the data of the reply. Code «L» in hexadecimal 4Ch in order to request the current value of the display.

End of block: The CR code. Hexadecimal code 0Dh.

	Start	High Address	Low Address	Code to get data	End
ASCII	@	0 a 9	0 a 9	L	CR
HEXA	40	30 a 39	30 a 39	4C	0D

Reply block:

Block header: Always is the character @. Hexadecimal code 41h.

Network address: Comprised of 2 characters in ASCII code hexadecimal. The first character is the upper part of the address. The second character is the lower part of the address.

Data: The reply from the VDU is divided into two parts: the reply of the value of the display and the reply of the activation state of the relays. If the unit does not possess the relay option, the reply indicates that the relays are inactive.

The reply code of the value is «RL» in hexadecimal 52h 4Ch, followed by 8 characters with the value of the VDU. The first character corresponds to the greatest weight.

The reply code of the state of the relays is «RR» in hexadecimal 52h52h, followed by 2 characters which indicate the state of relay 1 and relay 2. The coding is: = 0 (30h) Deactivated, = 1(31h) Activated.

End of block: The CR code. The hexadecimal code 0Dh.

	Start	High Address	Low Address	Data																End
ASCII	@	0 a 9	0 a 9	R	L	d7	d6	d5	d4	d3	d2	d1	d0	R	R	r0	r1	C	c0	CR
HEXA	40	30 a 39	30 a 39	52	4C									52	52			43		0D

Examples:

Request for the display value to be sent to a unit located at address 01 of the network.

	Start	High Address	Low Address	Code to get data	End
ASCII	@	0	1	L	CR
HEXA	40	30	31	4C	0D

Reply from the display.

Received value = 2.514

Relay 1 = ON. Relay 2 = OFF.

Digits colour: Red.

	Start	High Address	Low Address	Data																End
ASCII	@	0	1	R	L	d7	d6	d5	d4	d3	d2	d1	d0	R	R	r0	r1	C	c0	CR
HEXA	40	30	31	52	4C	20	20	20	32	2E	35	31	34	52	52	31	30	43	30	0D

Other example replay

Received value: -3.119

Relay 1 = OFF. Relay 2 = OFF.

Digits colour: Green

	Start	High Address	Low Address	Data																End
ASCII	@	0	1	R	L	d7	d6	d5	d4	d3	d2	d1	d0	R	R	r0	r1	C	c0	CR
HEXA	40	30	31	52	4C	20	20	2D	33	2E	31	31	39	52	52	30	30	43	31	0D

6. RELAY OUTPUT OPTION AND COLOUR OPTION.

There is a great link between relay output option and colour option because both uses the same alarm levels defined in the relay option, although is possible to have the colour option without the relay output option.

The equipments which possess the relay output option (DN1_9ATR. See Section 1.1) may generate control and alarm signals for their use by other units. The trigger level of the relay can be delayed with a timer or by a hysteresis value. The activation of the relay may be programmed so that it acts above or below the programmed trigger level.

The equipments which posses the colour option may be programmed to display the value using colour red, green or yellow.

The relation between the display colour and the display value is given by the relay output set point. With 2 relays is possible to define 4 levels and 4 parameters.

- Parameter **nr** : No relays ON.
- Parameter **r1** : Relay 1 ON.
- Parameter **r2** : Relay 2 ON.
- Parameter **r3** : Relays 1 and 2 ON.

For each parameter the three colours (Red, green or yellow) may be programmed.

Relay output option parameters are detailed in section 6.4.

6.1 Characteristics of the relay output option.

SPDT contact.

Maximum current:

Resistive load 5A

Inductive load 5A

Maximum voltage: 60V AC/DC

6.2 Wiring of relay output

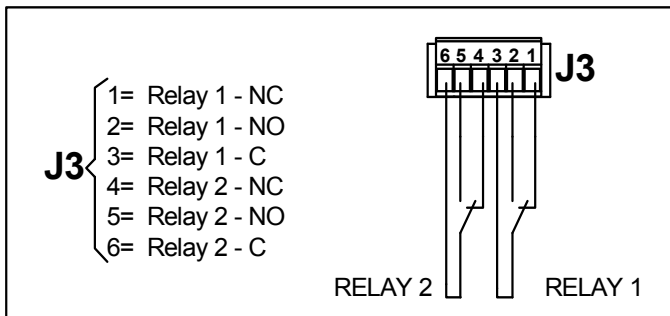

Position of **J3** connector on page 13

6.3 Modifying parameters of relay output option.

In order to configure the parameters, one must access the parameter modifying menu according to how it is detailed in Section 4.3.2. The parameters of the serial line are accessed from the rLS symbol.

6.4 Parameters description of relay output.



Selection menu for relay output. Upon pressing ENTER the menu is accessed.



Relay 1 configuration. After 2 seconds, the last value programmed is displayed and permitted to be modified. Upon pressing ENTER the value is validated and the next parameter is accessed. Each one of the two digits has a distinct function.

Left digit		Right digit	
0	On if Value > Setpoint	0	Delay
1	On if Value < Setpoint	1	Hysteresis
2	Always off		



Delay time or hysteresis value of relay 1. After 2 seconds, the last value programmed is displayed and permitted to be modified. Upon pressing ENTER the value is validated and the next parameter is accessed.



Set point value of relay 1. After 2 seconds, the last value programmed is displayed and permitted to be modified. Upon pressing ENTER the value is validated and the next parameter is accessed.



Relay 2 configuration. After 2 seconds, the last value programmed is displayed and permitted to be modified. Upon pressing ENTER the value is validated and the next parameter is accessed. Each one of the two digits has a distinct function.

Left digit		Right digit	
0	On if Value > Setpoint	0	Delay
1	On if Value < Setpoint	1	Hysteresis
2	Always off		



Delay time or hysteresis value of relay 2. After 2 seconds, the last value programmed is displayed and permitted to be modified. Upon pressing ENTER the value is validated and the next parameter is accessed.



Set point value of relay 2. After 2 seconds, the last value programmed is displayed and permitted to be modified. Upon pressing ENTER the value is validated and the next parameter is accessed.

Output relay option

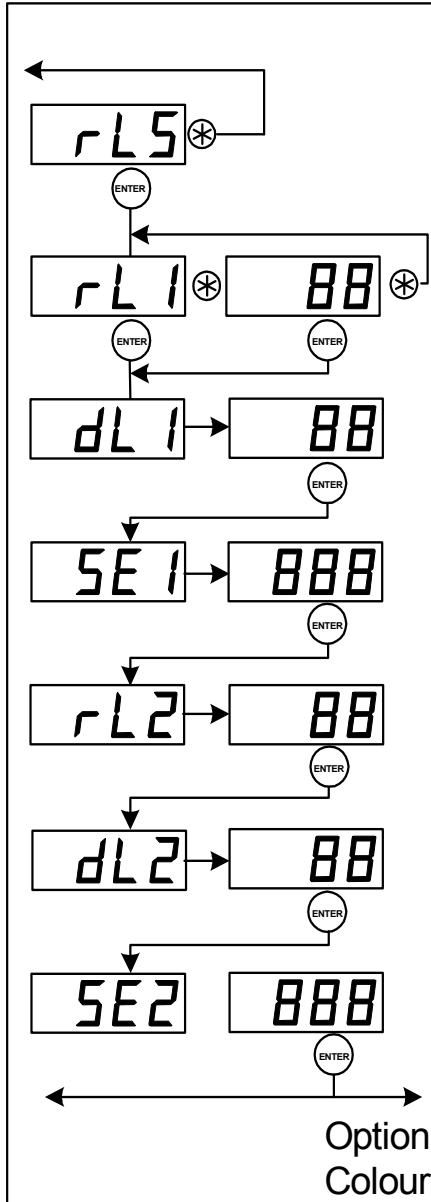

6.5 Parameters description of colour option.

If you have the colour option the set up colour parameters will be shown after the relay output parameters. It is not necessary to have the relay output option to use the colour option although both use the same parameters.

The programmed colour is the colour that you see.



Colour when no one relay ON. To change the colour push (+) key. Upon pressing ENTER the value is validated.



Colour when relay 1 is ON. To change the colour push (+) key. Upon pressing ENTER the value is validated.



Colour when relay 2 is ON. To change the colour push (+) key. Upon pressing ENTER the value is validated.



Colour when relay 1 and 2 are ON. To change the colour push (+) key. Upon pressing ENTER the value is validated.

Option: Colour

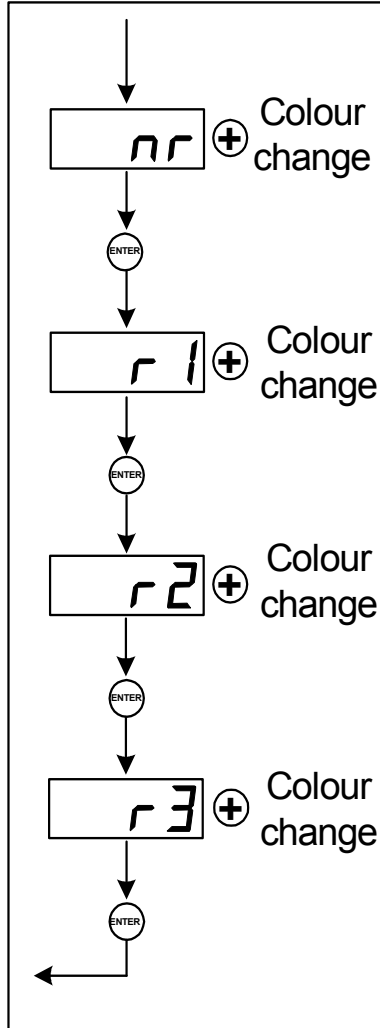

DECLARATION OF CONFORMITY



Tetralec Electronica Industrial, S.L.
c/ Severo Ochoa, 80
Polígono Industrial Font del Ràdium
08403 Granollers

As the manufacturer of the brand **LARTET** equipment:

Numeric display with serial interface.

Model: DN-109AT in all versions.

Model: DN-119AT in all versions.

Model: DN-129AT in all versions.

Model: DN-189AT in all versions.

We state under own responsibility that the above mentioned product complies with the following European:

Regulation: 73/23/CEE Regulation of low voltage and modification 93/68/CEE
Standard UNE-EN61010-1 Security in electric equipment

Regulation: 89/336/CEE Regulation of electromagnetic compatibility and modifications 92/31/CEE and 93/68/CEE

Standard UNE-EN61000-6-4 Generic emission standard. Industrial environment

Standard UNE-EN61000-6-2 Generic immunity standard. Industrial environment

Granollers, 15 of June 2009

A handwritten signature in blue ink, appearing to read 'J. Bisbe', with a long horizontal stroke extending to the right.

Josep M^a Bisbe
Technical Manager