

OPERATION MANUAL
FOR DISPLAYS OF
SERIES DN-109AP, DN-119AP, DN-129AP and DN-189AP



Index

1-INTRODUCTION	1
1.1 Model reference structure	2
2-GENERAL SPECIFICATIONS	3
2.1 Electrical characteristics of DN-109AP	3
2.1.1 Dimensions of displays DN-109iAP (Stainless steel box)	3
2.1.2 Dimensions of displays DN-109AP	5
2.1.3 Displays weight DN-109AP	5
2.2 Electrical characteristics of DN-119AP	6
2.2.1 Dimensions of displays DN-119AP	8
2.2.2 Displays weight DN-119AP	8
2.3 Electrical characteristics of DN-129AP	9
2.3.1 Dimensions of displays DN-129AP	10
2.3.2 Displays weight DN-129AP	10
2.4 Electrical characteristics of DN-189AP	12
2.4.1 Dimensions of displays DN-189AP	14
2.4.2 Displays weight DN-189AP	14
3. INSTALLATION	16
3.1 Contents of the package	16
3.2 Initial set up	16
3.3 Position of connectors and buttons	17
3.4 Power supply	17
3.5 Input signal connection	18
3.5.1 Voltage input. 4 wire connection. External excitation	18
3.5.2 Voltage input. 3 wire connection. External excitation	18
3.5.3 Voltage input. 4 wire connection. Excitation supplied by display	19
3.5.4 Voltage input. 3 wire connection. Excitation supplied by display	19
3.5.5 Current input. 4 wire connection. External excitation	20
3.5.6 Current input. 3 wire connection. External excitation	20
3.5.7 Current input. 2 wire connection. External excitation	21
3.5.8 Current input. 4 wire connection. Excitation supplied by display	21
3.5.9 Current input. 3 wire connection. Excitation supplied by display	22
3.5.10 Current input. 2 wire connection. Excitation supplied by display	22
4. OPERATION	23
4.1 Initial Start UP	23
4.2 Power up test	23
4.3 Programming the parameters	23
4.3.1 Display errors	24
4.3.2 Enter to modify parameters	24
4.3.3 Parameters description	25
5. SERIAL LINE OPTION	28
5.1 Characteristics of the serial line	28
5.2 Wiring of serial line input	28
5.3 Modifying parameters of serial line option	30
5.3.1 Parameters description of serial line option	30
5.4 Communication Protocol	32
6. RELAY OUTPUT OPTION AND COLOUR OPTION	34
6.1 Characteristics of the relay output option	34
6.2 Wiring of relay output	34
6.3 Modifying parameters of relay output option	35
6.4 Parameters description of relay output option	35
6.5 Parameters description of colour option	37

DECLARATION OF CONFORMITY CE

1. INTRODUCTION.

The numerical displays for series **DN-109AP, DN-119AP, DN-129AP and DN-189AP (DN-1_9AP)**, are industrial displays with analogue input for the control processes. All the models are manufactured in versions of 3, 4 or 5 digits, with one or two display sides.

The large digit display size **DN-109AP of 57mm, DN-119AP of 100mm, DN-129AP of 250mm and DN-189 of 180mm** with a legible distance from 30m to 120m, is one of the main characteristics.

The colour option, only available in some models, lets you select the digit colour between red, green and yellow.

All the equipment is provided completely calibrated, with the data stored in the memory non-volatile, eliminating the use of trimming potentiometers.

Available options:

- Colour option (**C**) Available to models DN-109 and DN-119.
- 2 Relay outputs. (**R**) Available to all models.
- Serial line. (**X**) To read the displayed value from a computer using a RS-232 or RS-485 connection. Available to all models.
- Protection degree IP65. (**e**) Available to models DN-109, DN-119 and DN-189
- Outdoor luminosity. (**h**). Available to models DN-119 and DN-189.
- Power supply 24VCC. Available to all models.

Available models from 3 to 5 digits, with 1 or 2 displaying sides.

Other models:

Within the visual display series **DN-1_9** other models are available for the following applications:

DN-1_9AT analog input for PT-100, thermocouples J, K, T.

DN-1_9X control by serial line with Modbus, ASCII, Omron Host-Link and Siemens S7-200 protocols.

DN-1_9P control by digital inputs with BCD control, counter, tachometer, chronometer and binary.

DN-1_9ND control by DeviceNet network.

DN-1_9NE control by Ethernet. TCP/IP and Modbus/TCP.

DN-1_9NP control by Profibus-DP network.

DN-1_9NW control by Wifi. TCP/IP and Modbus/TCP.

DN-1_9TH Ambient temperature and relative humidity.

Option summary table

		IP65	Outdoor luminosity	2 Sides	Color Option
DN-109	3, 4 or 5 Digits	YES	NO	YES	YES
DN-119	3, 4 or 5 Digits	YES	YES	YES	NO
		YES	NO	YES	YES
DN-129	3, 4 or 5 Digits	NO	NO	YES	NO
DN-189	3, 4 or 5 Digits	YES	YES	YES	NO

1.1 Model reference structure

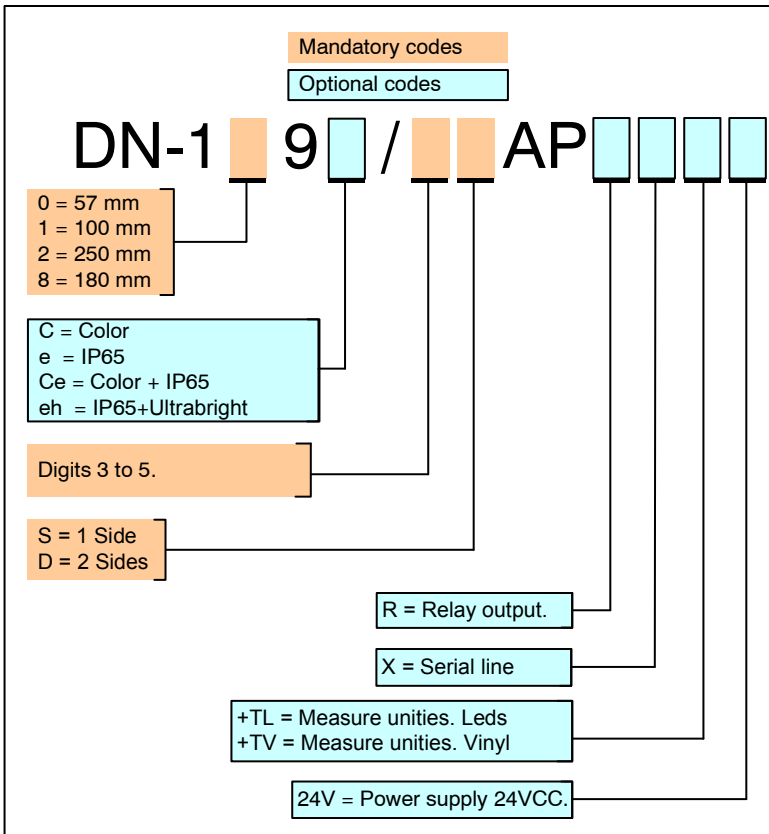

The model reference structure depends on installed options.

Some options are not available to all equipments. (Colour, IP65)

In this manual, we use **DN-109AP** when refer to **DN-109** with process input, independently of digits number, displaying sides and installed options.

In this manual, we use **DN-119AP** when refer to **DN-119** with process input, independently of digits number, displaying sides and installed options.

In this manual, we use **DN-129AP** when refer to **DN-129** with process input, independently of digits number, displaying sides and installed options.

In this manual, we use **DN-189AP** when refer to **DN-189** with process input, independently of digits number, displaying sides and installed options.

2. GENERAL SPECIFICATIONS

2.1 Electrical characteristics of DN-109AP.

Power supply	100VAc to 240VAC 50/60Hz
Consumption	22VA
Display	7 seg. 57mm + decimal point
.....	Red colour led.
Colour option.....	Colours Red, Green, Yellow.
Text option:.....	White Vinyl
Readable from	30 m.
Parameters memory.....	Eeprom

Input signal

Configuration..... Differential asymmetrical.

Voltage input

Range

Resolution.....

Input impedance.....

Current input

Range

Resolution.....

Input impedance.....

Output excitation.....

Accuracy to 22° ±5°C

Maximum error

Temperature coefficient.....

Warm up time.....

Conversion method

Technique

Resolution.....

Rate

Display

Resolution 3 digits displays

Resolution 4 digits displays

Resolution 5 digits displays

Over-range 3 digits displays.....

Over-range 4 and 5 digits displays.....

Parameter error. IP1 > IP2.....

Non input signal or polarity inverted

Over-range input signal

Environmental conditions

Operating temperature.....

Storage temperature

Relative humidity.....

Maximum environmental lighting.....

DN-109AP Protection degree.....

DN-109eAP Protection degree.....

Characteristics summary table

n = Number of digits	n = Number of digits	Protecti on	Relay outputs	Serial line	Number of sides
DN-109/nSAP	DN-109C/nSAP	IP-41	NO	NO	1
DN-109/nDAP	DN-109C/nDAP	IP-41	NO	NO	2
DN-109/nSAPX	DN-109C/nSAPX	IP-41	NO	SI	1
DN-109/nDAPX	DN-109C/nDAPX	IP-41	NO	SI	2
DN-109/nSAPR	DN-109C/nSAPR	IP-41	SI	NO	1
DN-109/nDAPR	DN-109C/nDAPR	IP-41	SI	NO	2
DN-109/nSAPXR	DN-109C/nSAPXR	IP-41	SI	SI	1
DN-109/nDAPXR	DN-109C/nDAPXR	IP-41	SI	SI	2
DN-109e/nSAP	DN-109Ce/nSAP	IP-65	NO	NO	1
DN-109e/nDAP	DN-109Ce/nDAP	IP-65	NO	NO	2
DN-109e/nSAPX	DN-109Ce/nSAPX	IP-65	NO	SI	1
DN-109e/nDAPX	DN-109Ce/nDAPX	IP-65	NO	SI	2
DN-109e/nSAPR	DN-109Ce/nSAPR	IP-65	SI	NO	1
DN-109e/nDAPR	DN-109Ce/nDAPR	IP-65	SI	NO	2
DN-109e/nSAPXR	DN-109Ce/nSAPXR	IP-65	SI	SI	1
DN-109e/nDAPXR	DN-109Ce/nDAPXR	IP-65	SI	SI	2

Available models from 3 to 5 digits.

Option colour available on all models DN-109/AP

2.1.1 Dimensions of displays DN-109iAP (Stainless steel box).

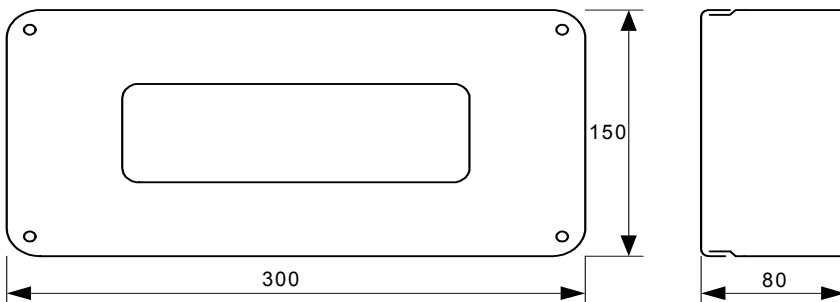

Available models from 4 to 5 digits.

Option colour available on all models DN-109i/AP

Protection degree IP65.

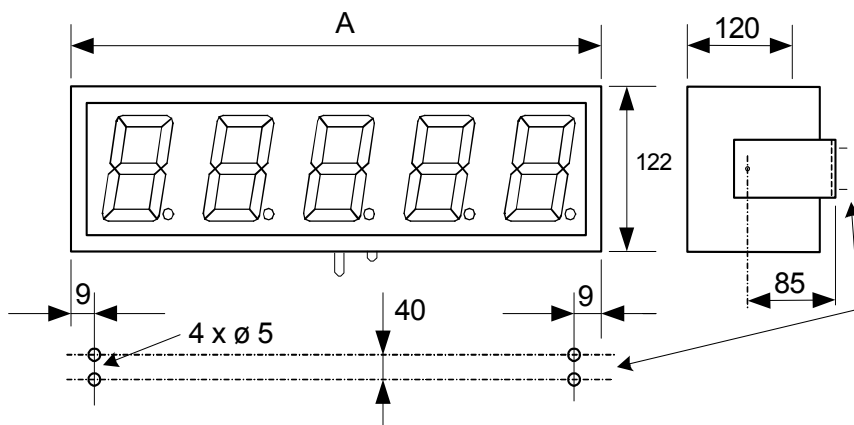
2.1.2 Dimensions of displays DN-109AP.

A according to digit's number

n (digit's num.)	3	4	5
DN-109(C)(e)/SnAP	210	288	288
DN-109(C)(e)/SnAP+T	306	384	384
DN-109(C)(e)/DnAP	----	288	288
DN-109(C)(e)/DnAP+T	306	384	384

C= Colour e= IP65

2.1.3 Displays weight DN-109AP.

n (digit's num.)	3	4	5
DN-109(C)(e)/SnAP	2 kg	2 kg	3 kg
DN-109(C)(e)/SnAP+T	3 kg	3 kg	3 kg
DN-109(C)(e)/DnAP	----	2 kg	3 kg
DN-109(C)(e)/DnAP+T	3 kg	3 kg	3 kg

C= Colour e= IP65

2.2 Electrical characteristics of DN-119AP.

Power supply	100VAc to 240VAC 50/60Hz
Consumption	26VA
Display	7 seg. 100mm + decimal point
.....	Red colour led.
Colour option	Colours Red, Green, Yellow.
Text option:	White Vinyl
Readable from	50 m.
Parameters memory	Eeprom

Input signal

Configuration

Differential asymmetrical.

Voltage input

Range	±10V DC
-------------	---------

Resolution	0.5 mV
------------------	--------

Input impedance	1 MOhm
-----------------------	--------

Current input

Range	±20mA DC
-------------	----------

Resolution	5 μ A
------------------	-----------

Input impedance	12.1 Ohm
-----------------------	----------

Output excitation	24V DC – 40mA
-------------------------	---------------

Accuracy to 22° ±5°C

Maximum error	±(0,1% of reading + 3 digits)
---------------------	-------------------------------

Temperature coefficient	100 ppm/ °C
-------------------------------	-------------

Warm up time	5 minutes
--------------------	-----------

Conversion method

Technique	Sigma-Delta
-----------------	-------------

Resolution	16 bits
------------------	---------

Rate	25/ s
------------	-------

Display

Resolution 3 digits displays	-199 / 999
------------------------------------	------------

Resolution 4 digits displays	-1999 / 9999
------------------------------------	--------------

Resolution 5 digits displays	-19999 / 99999
------------------------------------	----------------

Over-range 3 digits displays	-OE/ OuE
------------------------------------	----------

Over-range 4 and 5 digits displays	-OuE / OuE
--	------------

Parameter error. IP1 > IP2	E0
----------------------------------	----

Non input signal or polarity inverted	E2
---	----

Over-range input signal	E3
-------------------------------	----

Environmental conditions

Operating temperature	0° to 50° C
-----------------------------	-------------

Storage temperature	-10° to 60°C
---------------------------	--------------

Relative humidity	5 a 95% non condensation.
-------------------------	---------------------------

DN-119AP and DN-119eAP Maximum environmental lighting	1000 lux
---	----------

DN-119AP Protection degree	IP41.
----------------------------------	-------

DN-119ehAP Maximum environmental lighting	Outdoor
---	---------

DN-119eAP and DN-119ehAP Protection degree	IP65.
--	-------

Characteristics summary table

n = Number of digits	n = Number of digits	n = Number of digits	Protecti on	Relay outputs	Serial line	Number of sides
DN-119/nSAP	DN-119C/nSAP	-----	IP-41	NO	NO	1
DN-119/nDAP	DN-119C/nDAP	-----	IP-41	NO	NO	2
DN-119/nSAPX	DN-119C/nSAPX	-----	IP-41	NO	SI	1
DN-119/nDAPX	DN-119C/nDAPX	-----	IP-41	NO	SI	2
DN-119/nSAPR	DN-119C/nSAPR	-----	IP-41	SI	NO	1
DN-119/nDAPR	DN-119C/nDAPR	-----	IP-41	SI	NO	2
DN-119/nSAPXR	DN-119C/nSAPXR	-----	IP-41	SI	SI	1
DN-119/nDAPXR	DN-119C/nDAPXR	-----	IP-41	SI	SI	2
DN-119e/nSAP	DN-119Ce/nSAP	DN-119eh/nSAP	IP-65	NO	NO	1
DN-119e/nDAP	DN-119Ce/nDAP	DN-119eh/nDAP	IP-65	NO	NO	2
DN-119e/nSAPX	DN-119Ce/nSAPX	DN-119eh/nSAPX	IP-65	NO	SI	1
DN-119e/nDAPX	DN-119Ce/nDAPX	DN-119eh/nDAPX	IP-65	NO	SI	2
DN-119e/nSAPR	DN-119Ce/nSAPR	DN-119eh/nSAPR	IP-65	SI	NO	1
DN-119e/nDAPR	DN-119Ce/nDAPR	DN-119eh/nDAPR	IP-65	SI	NO	2
DN-119e/nSAPXR	DN-119Ce/nSAPXR	DN-119eh/nSAPXR	IP-65	SI	SI	1
DN-119e/nDAPXR	DN-119Ce/nDAPXR	DN-119eh/nDAPXR	IP-65	SI	SI	2

Available models from 3 to 5 digits.

Option colour available on all models DN-109/AP except for outdoor luminosity equipments.

2.2.1 Dimensions of displays DN-119AP.

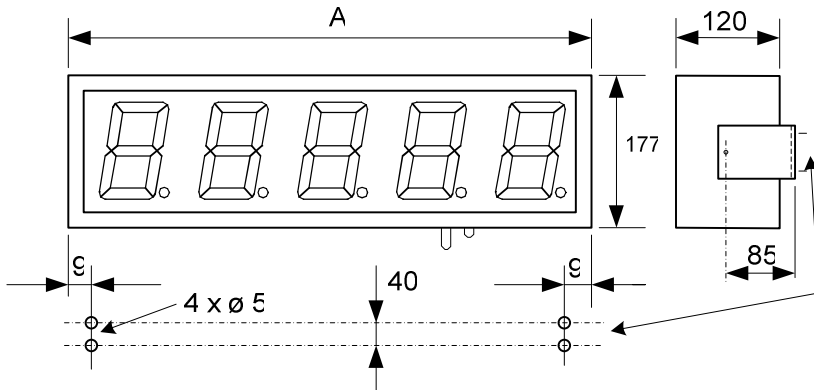

A according to digit's number

n (digit's num.)	3	4	5
DN-119(C)(e)(h)/SnAP	324	414	504
DN-119(C)(e)(h)/SnAP+T	504	594	684
DN-119(C)(e)(h)/DnAP	324	414	504
DN-119(C)(e)(h)/DnAP+T	504	594	684

C= Colour e=IP65 h=outdoor luminosity

2.2.2 Displays weight DN-119AP.

n (digit's num.)	3	4	5
DN-119(C)(e)(h)/SnAP	4 kg	4 kg	4,5 kg
DN-119(C)(e)(h)/SnAP+T	4,5 kg	4,5 kg	5 kg
DN-119(C)(e)(h)/DnAP	4 kg	4,5 kg	4,5 kg
DN-119(C)(e)(h)/DnAP+T	4,5 kg	4,5 kg	5 kg

C= Colour e=IP65 h=outdoor luminosity

2.3 Electrical characteristics of DN-129AP.

Power supply	100VAc to 240VAC 50/60Hz
Consumption	40VA
Display	7 seg. 250mm + decimal point
	Red colour led.
Text option:	White Vinyl
Readable from	120 m.
Parameters memory	Eeprom

Input signal	
Configuration	Differential asymmetrical.
Voltage input	
Range	±10V DC
Resolution	0.5 mV
Input impedance	1 MOhm
Current input	
Range	±20mA DC
Resolution	5 µA
Input impedance	12.1 Ohm
Output excitation	24V DC – 40mA

Accuracy to 22° ±5°C

Maximum error	±(0,1% of reading + 3 digits)
Temperature coefficient	100 ppm/ °C
Warm up time	5 minutes

Conversion method

Technique	Sigma-Delta
Resolution	16 bits
Rate	25/ s

Display

Resolution 3 digits displays	-199 / 999
Resolution 4 digits displays	-1999 / 9999
Resolution 5 digits displays	-19999 / 99999
Over-range 3 digits displays	-OE/ OuE
Over-range 4 and 5 digits displays	-OuE / OuE
Parameter error. IP1 > IP2	E0
Non input signal or polarity inverted	E2
Over-range input signal	E3

Environmental conditions

Operating temperature	0° to 50° C
Storage temperature	-10° to 60°C
Relative humidity	5 a 95% non condensation.
Maximum environmental lighting	2000 lux
Protection degree	IP41.

Characteristics summary table

n = Number of digits	Protection	Relay outputs	Serial line	Number of sides
DN-129/nSAP	IP-41	NO	NO	1
DN-129/nDAP	IP-41	NO	NO	2
DN-129/nSAPX	IP-41	NO	YES	1
DN-129/nDAPX	IP-41	NO	YES	2
DN-129/nSAPR	IP-41	YES	NO	1
DN-129/nDAPR	IP-41	YES	NO	2
DN-129/nSAPXR	IP-41	YES	YES	1
DN-129/nDAPXR	IP-41	YES	YES	2

Available models from 3 to 5 digits.

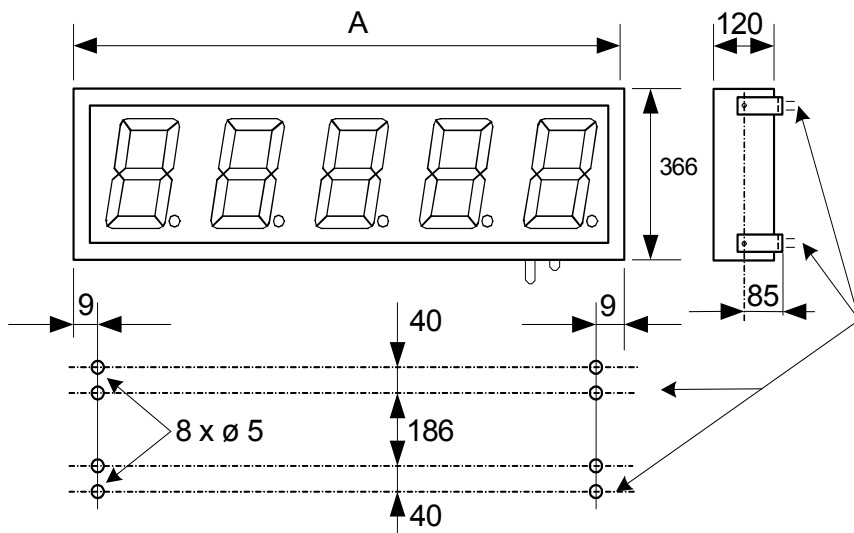
2.3.1 Dimensions of displays DN-129AP.

A according to digit's number

n (digit's num.)	3	4	5
DN-129/SnAP	750	985	1220
DN-129/SnAP+T	1220	1455	1690
DN-129/DnAP	750	985	1220
DN-129/DnAP+T	1220	1455	1690

2.3.2 Displays weight DN-129AP.

n (digit's num.)	3	4	5
DN-129/SnP	8,5 kg	10 kg	11,5 kg
DN-129/SnP+T	11,5 kg	13 kg	15 kg
DN-129/DnP	10 kg	12,5 kg	14,5 kg
DN-129/DnP+T	14 kg	16 kg	18,5 kg

2.4 Electrical characteristics of DN-189AP.

Power supply	100VAc to 240VAC 50/60Hz
Consumption	26VA
Display	7 seg. 250mm + decimal point
	Red colour led.
Text option:	White Vinyl
Readable from	90 m.
Parameters memory	Eeprom

Input signal

Configuration..... Differential asymmetrical.

Voltage input

Range..... $\pm 10V$ DC

Resolution..... 0.5 mV

Input impedance..... 1 MOhm

Current input

Range..... $\pm 20mA$ DC

Resolution..... 5 μA

Input impedance..... 12.1 Ohm

Output excitation..... 24V DC – 40mA

Accuracy to 22° $\pm 5^{\circ}C$

Maximum error..... $\pm(0,1\%$ of reading + 3 digits)

Temperature coefficient..... 100 ppm/ $^{\circ}C$

Warm up time..... 5 minutes

Conversion method

Technique..... Sigma-Delta

Resolution..... 16 bits

Rate..... 25/ s

Display

Resolution 3 digits displays..... -199 / 999

Resolution 4 digits displays..... -1999 / 9999

Resolution 5 digits displays..... -19999 / 99999

Over-range 3 digits displays..... -OE/ OuE

Over-range 4 and 5 digits displays..... -OuE / OuE

Parameter error. IP1 > IP2..... E0

Non input signal or polarity inverted..... E2

Over-range input signal..... E3

Environmental conditions

Operating temperature..... 0° to 50° C

Storage temperature..... -10° to 60°C

Relative humidity..... 5 a 95% non condensation.

DN-189AP and DN-189eAP Maximum environmental lighting..... 2000 lux

DN-189AP Protection degree..... IP41.

DN-189ehAP Maximum environmental lighting..... Outdoor

DN-189eAP and DN-189ehAP Protection degree..... IP65.

Characteristics summary table

n = Number of digits	n = Number of digits	Protecti on	Relay outputs	Serial line	Number of sides
DN-189/nSAP	-----	IP-41	NO	NO	1
DN-189/nDAP	-----	IP-41	NO	NO	2
DN-189/nSAPX	-----	IP-41	NO	SI	1
DN-189/nDAPX	-----	IP-41	NO	SI	2
DN-189/nSAPR	-----	IP-41	SI	NO	1
DN-189/nDAPR	-----	IP-41	SI	NO	2
DN-189/nSAPXR	-----	IP-41	SI	SI	1
DN-189/nDAPXR	-----	IP-41	SI	SI	2
DN-189e/nSAP	DN-189eh/nSAP	IP-65	NO	NO	1
DN-189e/nDAP	DN-189eh/nDAP	IP-65	NO	NO	2
DN-189e/nSAPX	DN-189eh/nSAPX	IP-65	NO	SI	1
DN-189e/nDAPX	DN-189eh/nDAPX	IP-65	NO	SI	2
DN-189e/nSAPR	DN-189eh/nSAPR	IP-65	SI	NO	1
DN-189e/nDAPR	DN-189eh/nDAPR	IP-65	SI	NO	2
DN-189e/nSAPXR	DN-189eh/nSAPXR	IP-65	SI	SI	1
DN-189e/nDAPXR	DN-189eh/nDAPXR	IP-65	SI	SI	2

h= outdoor luminosity

Available models from 3 to 5 digits.

2.4.1 Dimensions of displays DN-189AP.

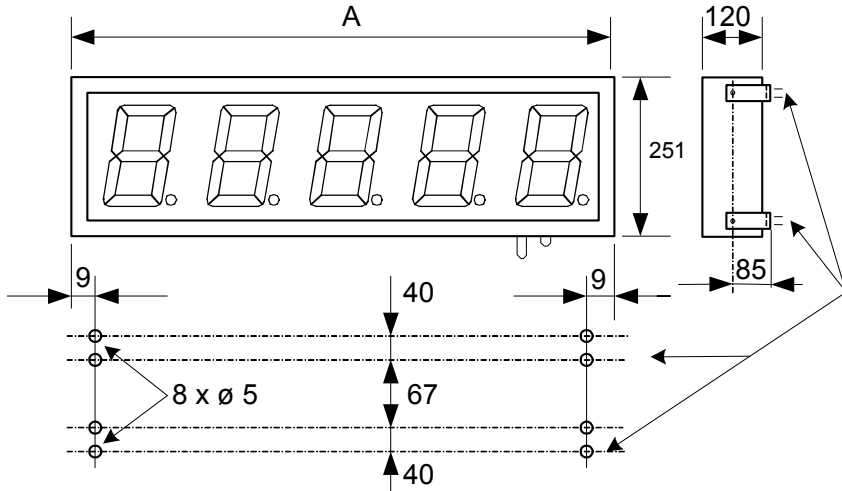

A according to digit's number

n (digit's num.)	3	4	5
DN-189(e)(h)/SnAP	500	660	820
DN-189(e)(h)/SnAP+T	820	980	1140
DN-189(e)(h)/DnAP	500	660	820
DN-189(e)(h)/DnAP+T	820	980	1140

e=IP65 h=outdoor luminosity

2.4.2 Displays weight DN-189AP.

n (digit's num.)	3	4	5
DN-189(e)(h)/SnAP	5 kg	6 kg	7,5 kg
DN-189(e)(h)/SnAP+T	7 kg	8 kg	9 kg
DN-189(e)(h)/DnAP	6 kg	7,5kg	8,5 kg
DN-189(e)(h)/DnAP+T	8 kg	9,5 kg	10,5 kg

e=IP65 h=outdoor luminosity

3. INSTALLATION

There are some considerations to take into account before installing **DN-1_9AP**.

The displays must neither be fixed to places close to vibration nor to places which exceed the limits of temperature and humidity specified in the display characteristics.

The protection degree of **DN-1_9AP** displays is IP41, which means that they are protected against the penetration of solid objects of more than 1mm diameter and against the vertical falling of drops. The protection degree of **DN-1_9e/AP** is IP65, which means that they are protected against dust and water jet.

The **DN-1_9AP** displays, must not be installed where the lighting level is higher than 1000 lux. They must be protected against direct sunlight.

The **DN-119eh/AP** and **DN-189eh/AP** may work on direct sunlight.

They must stay away from high frequency generators, which are frequent in soldering equipment U/F converters for motors.

**Displays DN-1_9eAP and DN-1_9ehAP:
To obtain the IP65 protection you must use the water resistant hood supplied with the display**

3.1. Contents of the package.

Before proceeding to the installation of the equipment, we recommend that you identify all the material which has been received. In the box, you will find the following material:

- Operation manual
- Visual Display Unit
- 2 Mounting brackets for the models DN-109/AP and DN-119/AP
- 4 Mounting brackets for the model DN-129/AP and DN-189/AP
- One bag containing: 1 Power lead connector, 1 connector for analogue input, 2 (4) knobs, 2(4) nylon washers.
- Equipment with IP65 option: 1 analog input connector hood.

3.2. Initial Setup.

Before connecting the display for the first time, you must setup the parameters depending on what output values you want. Follow steps on section 4.3 and the next ones to setup the parameters.

3.3 Position of connectors and buttons

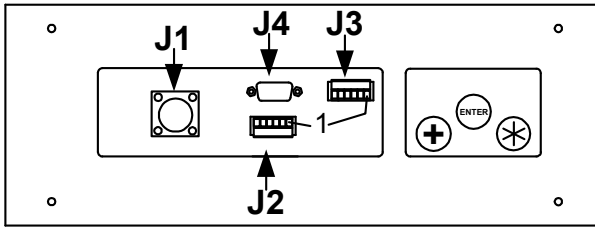

Fig. 3.1 Position of connectors and buttons

The signal connectors are situated in the lower part of the unit (fig. 3.1). Depending on the installed options, the unit will possess various types of connectors.

Connector **J2**: Analogue inputs.

Connector **J3**: Relay output. Units with the **R** option.

Connector **J4**: Serial line. Equipment with the **X** option.

The J1 power lead connector is situated in the lower part of the unit, except in DN-109/3AP models where this is in the upper part of the unit.

The buttons for configuration of the equipment are located in the lower part. They are identified with the symbols +, * and the text «ENTER».

3.4 Power supply.

Power supply must be from **100VAC to 240VAC, 50/60 Hz** or 24VDC optionally.

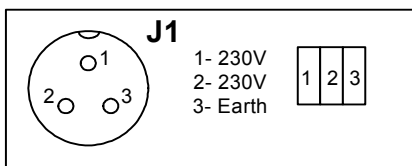

Fig. 3.2 Power supply 230VAC

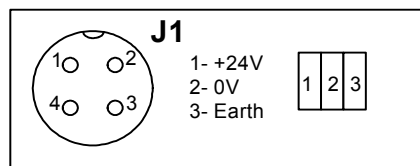

Fig. 3.3 Power supply 24V CC

The section of power supply conductors is in keeping with the consumption. The earth conductor will be minimum 1,5mm².

The supply connector is a three-contact type and is located at the bottom of the unit. The connection must be made according to figure 3.2 for power supply of 230VAC and according to figure 3.3 for power supply of 24VCC.

3.5 Input signal connection

In all the mountings, the connection of the inputs must be done using braided and insulated cable. The screen must only be connected to terminal 1 of the input connector.

Terminals 5 and 6 of J2 are output power. Terminals 5 and 6 of J2 must never be connected to a power supply.

3.5.1 Voltage input. 4 Wire connection. External excitation.

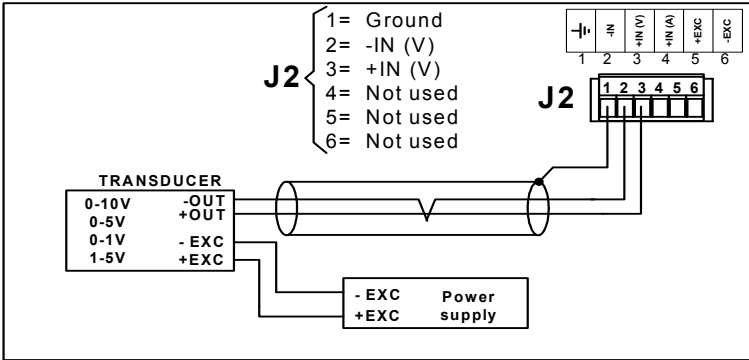

Position of **J2** connector on page 13

3.5.2 Voltage input. 3 Wire connection. External excitation.

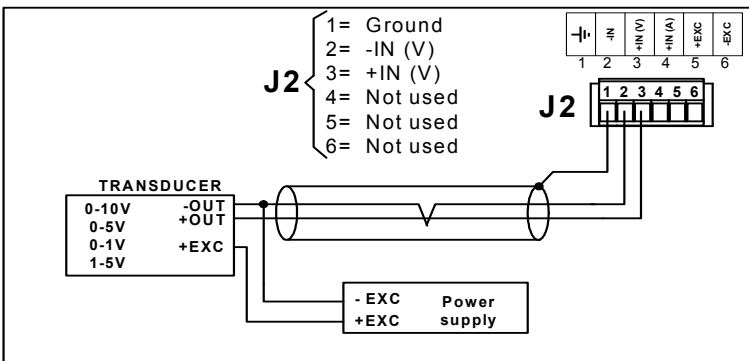

Position of **J2** connector on page 13

3.5.3 Voltage input. 4 Wire connection. Excitation supplied by display.

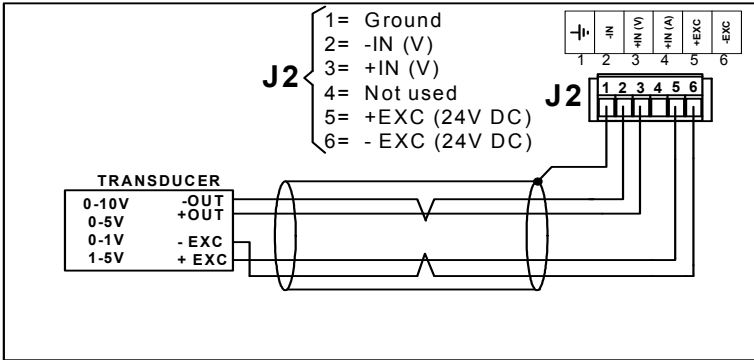

Position of **J2** connector on page 13

3.5.4 Voltage input. 3 Wire connection. Excitation supplied by display.

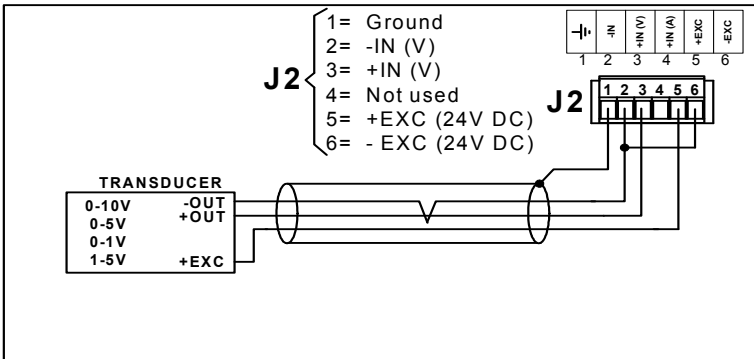

Position of **J2** connector on page 13

3.5.5 Current input. 4 Wire connection. External excitation.

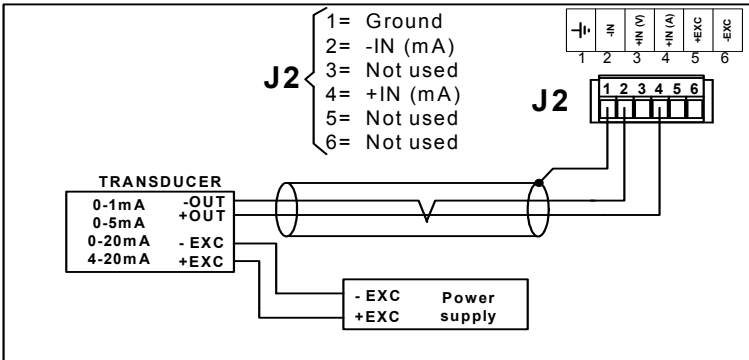

Position of **J2** connector on page 13

3.5.6 Current input. 3 Wire connection. External excitation.

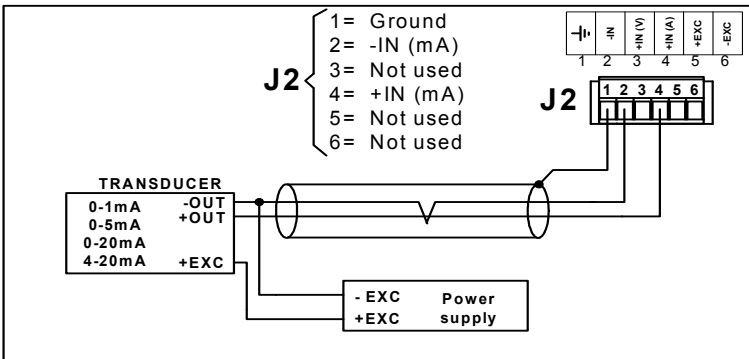

Position of **J2** connector on page 13

3.5.7 Current input. 2 Wire connection. External excitation.

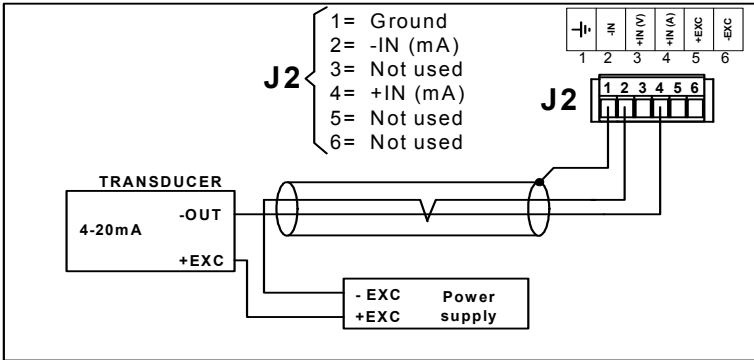

Position of **J2** connector on page 13

3.5.8 Current input. 4 Wire connection. Excitation supplied by display.

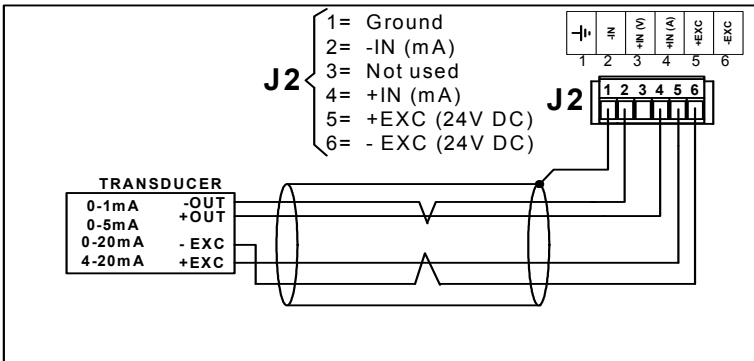

Position of **J2** connector on page 13

3.5.9 Current input. 3 Wire connection. Excitation supplied by display.

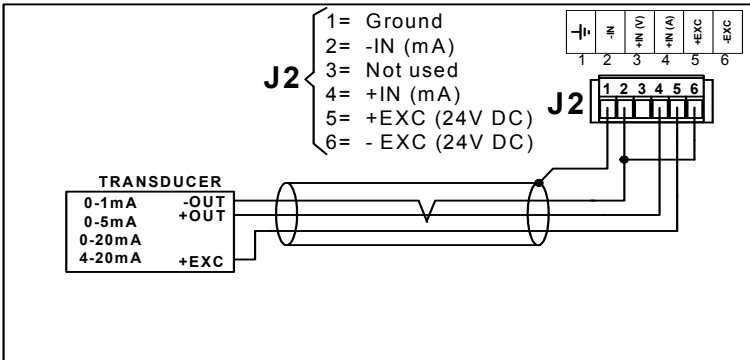

Position of **J2** connector on page 13

3.5.10 Current input. 4 Wire connection. Excitation supplied by display.

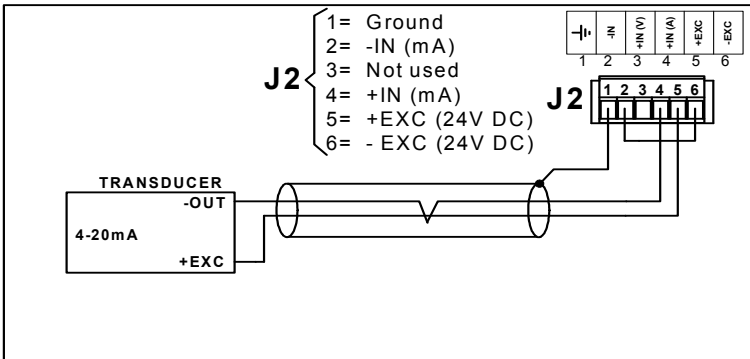

Position of **J2** connector on page 13

4. OPERATION

4.1 Initial Start UP

Before connecting the display for the first time, you must setup the parameters depending on what output values you want. Follow steps on section 4.3 and the next ones to setup the parameters.

Before connecting the display to the network, it must be checked that all connections have been set properly and that the display have been firmly placed.

4.2 Power up test

Every time the display is connected to the supply network, there is an initial reset, which check all the segments of the display. The test consist on the sequential lightening of all digits with value "8", all digits with value "0" and at last of all decimal points.

On the next step the version code is shown and the equipment is ready to work.

4.3 Programming the parameters

In addition to modifying the type of input (voltage or current), the range of the display must be programmed in order to adjust the value read to the value desired. The programming of the range is done by programming two points of the line. Each point is defined by a value from the analogue entry (IP1 and IP2) and a representation value in the display (dP1 and dP2). See Fig. 4.1. The maximum precision is achieved by programming the two points at the outer ends of the process.

In the processes in which the display value must vary in inverse relation to the input signal, one must assign the high display value to the low input value and the low display value to the high input value. See Fig.4.2

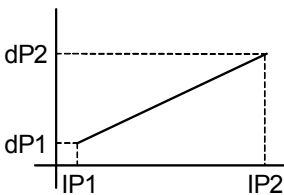

Fig. 4.1

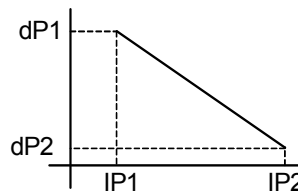

Fig. 4.2

The programming of the input values may be done in two ways: Entry by keys directly of the value (SCL) or by making the display read the input value and validating it through the keys. (tEA)

Programming through the keys (SCL): To be able to use this method, it is necessary to know the transducer specifications in the points IP1 and IP2 beforehand.

Programming by reading (tEA): To be able to use this method, it is necessary to have made the connection from the transducer to the display. When the values of IP1 and IP2 are shown, the current value read by the transducer is displayed instead of the last value programmed. Pressing ENTER validates the parameter.

Examples:

4-20mA humidity sensor.

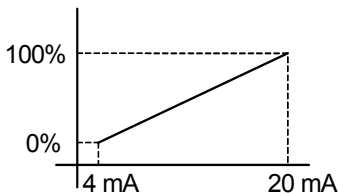

Program these parameters.

IP1	4,00	IP2	20,00
dP1	0	dP2	100

Speedometer dynamo 5V/2500 rpm

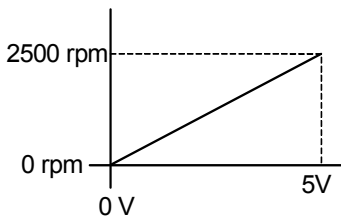

Program these parameters.

IP1	0,00	IP2	5,00
dP1	0	dP2	2500

4.3.1 Display errors

E0: Input parameter error: IP2 must be greater than IP1

E2: Low level input signal. Wire broken or polarity error. Input signal must be < 0.9 of IP1 or < -0.2 if IP1 is < 1 .

E3: High level input signal. Input signal must be > 1.1 of IP2.

E4: Overrun while teaching process.

-OE / OuE: Overrun on 3 digits displays.

-OuE / OuE: Overrun on 4 or 5 digit displays.

4.3.2 Enter to modify parameters.

To enter into the sequence for modifying parameters, one must press and hold the key * for three seconds. After this time, the word «Pro» will be displayed. Pressing the ENTER key, one accesses the configuration menu for input type, display value and the installed options. After configuring each one of the menus, the RUN mode is returned to for normal operation of the display.

The function of each key is the following:



Enter to modify parameters. Advance through the menu selections. Advance through the selection of digits.



Increase the value of one digit. Upon reaching 9, you can go on (or only back to 0, depending on the function of the digit).



Validate the value of a field. Change the parameter.

4.3.3 Parameters description

A rectangular box containing the text 'Pro' in a stylized, monospaced font.

The sequence for modifying parameters has been entered. Press ENTER to continue.

A rectangular box containing the text 'InP' in a stylized, monospaced font.

Input type menu. Upon pressing ENTER, the last type of input selected is displayed.

A rectangular box containing the text '-U-' in a stylized, monospaced font.

Voltage input selected. Press * to select the input current.

A rectangular box containing the text '-A-' in a stylized, monospaced font.

Input current selected. Press * to select voltage input.

A rectangular box containing the text 'dSP' in a stylized, monospaced font.

Display scale adjustment menu. Upon pressing ENTER, one can select the direct input of values (DSP) or input through read values (TEA)

A rectangular box containing the text 'SCL' in a stylized, monospaced font.

Upon pressing ENTER, one has direct access to the input of scale values.

A rectangular box containing the text 'TEA' in a stylized, monospaced font.

Upon pressing ENTER, one has direct access to the entry of input values 1 and 2 from the value read by the analogue input.

A rectangular box containing the text 'IP1' in a stylized, monospaced font.

Value of input 1. After 2 seconds, the last value programmed of input 1 is displayed (SCL mode) or the current value of the input (TEA mode), and is able to be modified. Upon pressing ENTER, the value is validated and the following parameter is accessed.

A rectangular box containing the text 'dP1' in a stylized, monospaced font.

Display value corresponding to input 1. After 2 seconds, the last value programmed of display 1 is shown, and modification is permitted. Upon pressing ENTER, the value is validated and the following parameter is accessed.

PdC

Position of the decimal point. After 2 seconds, the last value programmed is shown and is permitted to be modified. Upon pressing ENTER, the value is validated and the following parameter is accessed.

IP2

Value of input 2. After 2 seconds, the last value programmed of input 1 is displayed (SCL mode) or the current value of the input (tEA mode) and modification is permitted. Upon pressing ENTER, the value is validated and the following parameter is accessed.

dP2

Value of the display corresponding to input 2. After 2 seconds, the last value programmed of display 2 is shown and may be modified. Upon pressing ENETR, the value is validated and the following parameter is accessed.

r0U

In order to force to zero one or two digits at the display right. It is used to eliminate oscillations in the value. Valid values:
 =0 Don't force any value.
 =1 Force one digit to zero.
 =2 Force two digits to zero.

888

With this symbol, it is indicated that it is a numeric value which can be modified. Depending on the parameter and the number of digits of the unit, this can be from 1 to 5 digits. In order to modify it, the displacement. (*) and increase (+) keys are used. Upon reaching 9, it goes on to 0, except if this is a higher weight digit, in which case it will first go to -1, then to -, then back to 0.

-00

To display the -1value on the most left position digit the symbol - is used.

DISPLAYS WITH COLOUR OPTION:

To program the display colour see the paragraph:
 Relay option on Chapter 6.

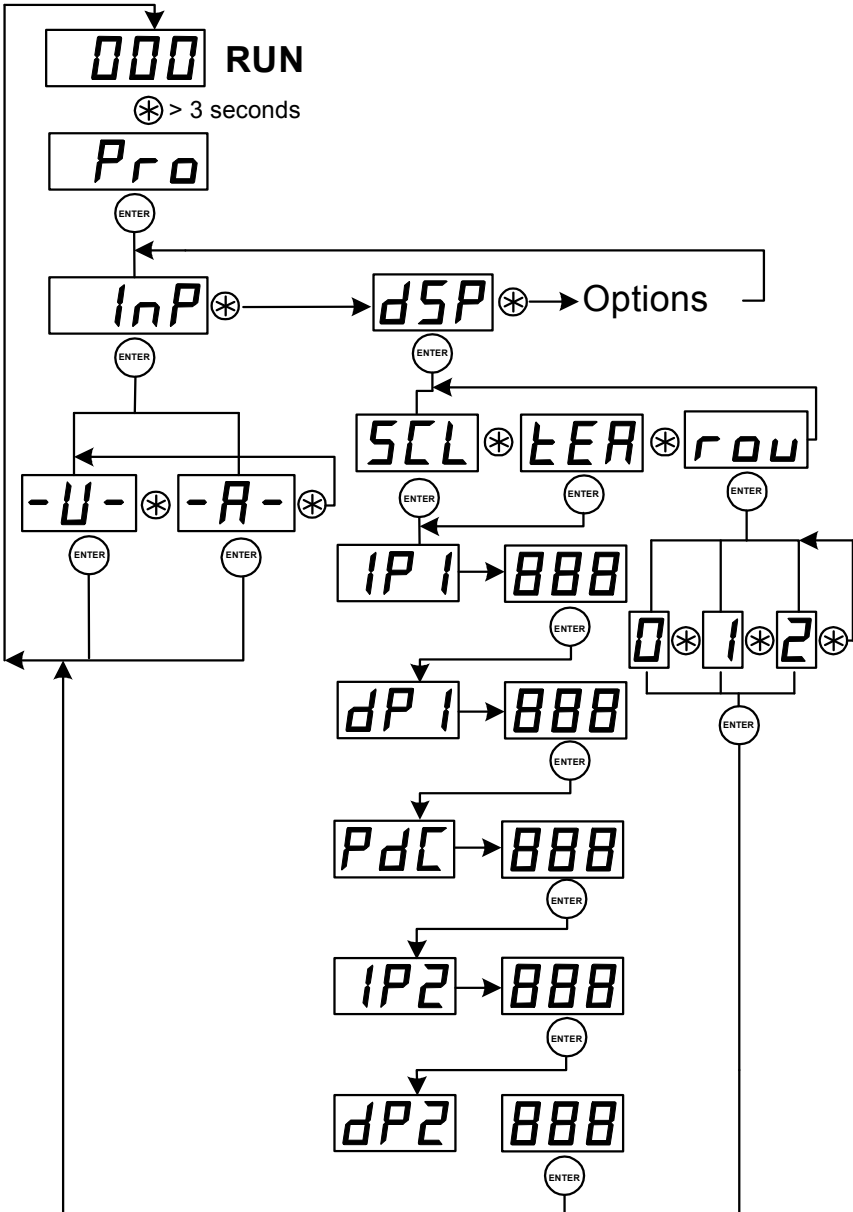

5. SERIAL LINE OPTION

The displays which possess the serial line option (**DN-1_9APX**. See Section 1.1) may communicate with a computer in order to carry out the parameter programming (through the DNWIN software) or in order to send the information of the analogue input to the computer.

All the units with the serial line input option have two kinds of connections: RS-232C and RS-485.

5.1 Characteristics of the serial line.

Only one DB9 Connector for RS-232C and RS-485.

Baud rate: 9600 and 19200.

Parity control: Even , odd, no parity.

Data bits: 7 or 8.

Stop bits: 1 or 2.

5.2 Wiring of serial line input.

DN-1_9APX series displays accept two types of serial input RS-232 and RS-485. The same connector is used for both inputs (type DB-9), and is located at the bottom of the equipment.

The selection of the series line type is done programming the parameters.

The wiring diagram is shown below:

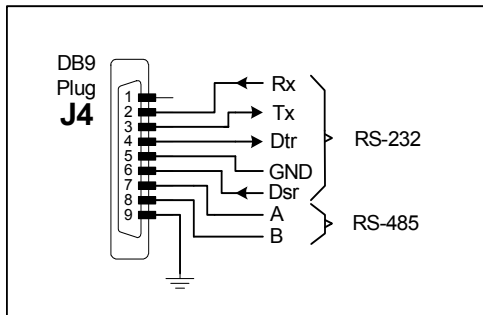

CONNECTOR SERIES DN-1_9APX

Position of **J4** connector on page 13

5.2.1 Wiring diagram between a DN-1_9APX and a PC using RS-232.

In a RS-232 connection the line length must not surpass **5m**. It is important to use shield cable and to connect the screen to pin 9 in the connector DB9. The network must avoid the proximity with high power lines.

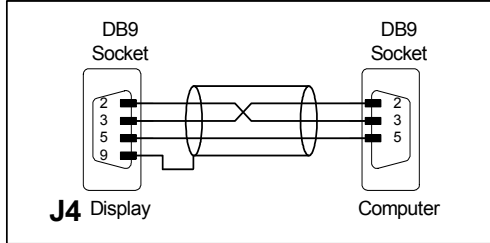

RS-232 connection between a DN-1_9APX and a PC

Position of **J4** connector on page 13.

The connector type (plug or socket) correspond to the cable.

5.2.2 RS-485 Connection between a DN-1_9APX and PC using a RS-232/422/485 Afeisa converter.

In a RS-485 connection the line length must not surpass 1000m, without amplifiers. It is necessary to use shielded pair cable and to connect the screen to pin 9 in the connector DB9. The network must avoid the proximity with high power lines. Branches from the network to the displays must be as short as possible. Resistors from the end of the line of 120 Ohm have to be set in order to assure a good working order of the network.

In connector DB9 there is place enough to set the resistance together with the connection.

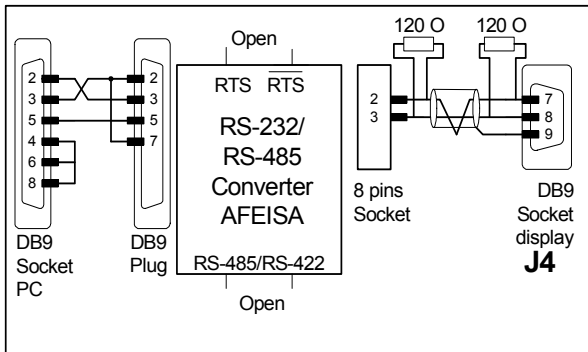

Position of **J4** connector on page 13.

The connector type (plug or socket) correspond to the cable.

5.3 Modifying parameters of serial line option.

In order to configure the parameters, one must access the parameter modifying menu according to how it is detailed in Section 4.3.2. The parameters of the serial line are accessed from the LSE symbol.

5.3.1 Parameters description of serial line option

LSE Selection menu for the serial line. Upon pressing ENTER the menu is accessed.

Addr Value of the display address on the network. After 2 seconds, the last value programmed is displayed and is permitted to be modified. Upon pressing ENTER the value is validated and the next parameter is accessed. The range of values is from 00 to 99.

BAU Baud rate. After 2 seconds, the last value programmed is displayed and permitted to be modified. Upon pressing ENTER the value is validated and the next parameter is accessed. The range of values is 9600(96) and 19200(192).

bid Data bits. After 2 seconds, the last value programmed is displayed and permitted to be modified. Upon pressing ENTER the value is validated and the next parameter is accessed. The range of values is 7 and 8.

b15 Stop bits. After 2 seconds, the last value programmed is displayed and permitted to be modified. Upon pressing ENTER the value is validated and the next parameter is accessed. The range of values is 1 and 2

PRr Parity. After 2 seconds, the last value programmed is displayed and permitted to be modified. Upon pressing ENTER the value is validated and the next parameter is accessed. The range of Even Parity (PrP), Odd Parity (PrI) and Non Parity (Prn)

LPL Type of serial line. After 2 seconds, the last value programmed is displayed and permitted to be modified. Upon pressing ENTER the value is validated and the next parameter is accessed. The range of values is RS-232C(232) and RS-485(485).

Serial line option

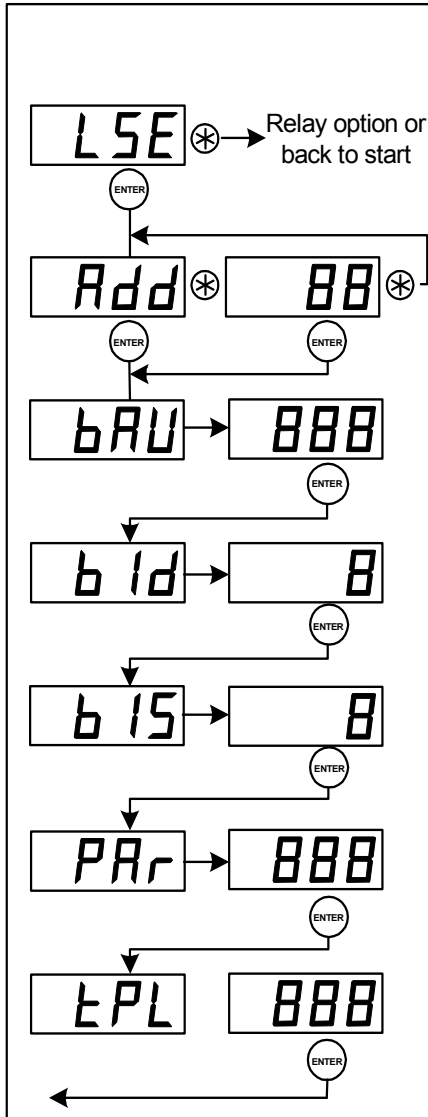

5.4 Communication protocol.

The communication protocol used is based in ASCII characters. The display unit always works in slave mode, which is to say that it waits to receive a correct raster (Query) in order to be able to return the raster with the data requested (Reply).

All the transmission blocks have the same structure: Header, network address, data and end of block.

Query block:

Block header: Always is the character @. Hexadecimal code 41h.

Network address: Comprised of 2 characters in ASCII code hexadecimal. The first character is the upper part of the address. The second character is the lower part of the address.

Data: This could be the query code or the data of the reply. Code «L» in hexadecimal 4Ch in order to request the current value of the display.

End of block: The CR code. Hexadecimal code 0Dh.

	Start	High Address	Low Address	Code to get data	End
ASCII	@	0 a 9	0 a 9	L	CR
HEXA	40	30 a 39	30 a 39	4C	0D

Reply block:

Block header: Always is the character @. Hexadecimal code 41h.

Network address: Comprised of 2 characters in ASCII code hexadecimal. The first character is the upper part of the address. The second character is the lower part of the address.

Data: The reply from the VDU is divided into two parts: the reply of the value of the display and the reply of the activation state of the relays. If the unit does not possess the relay option, the reply indicates that the relays are inactive.

The reply code of the value is «RL» in hexadecimal 52h 4Ch, followed by 8 characters with the value of the VDU. The first character corresponds to the greatest weight.

The reply code of the state of the relays is «RR» in hexadecimal 52h52h, followed by 2 characters which indicate the state of relay 1 and relay 2. The coding is: = 0 (30h) Deactivated, = 1(31h) Activated.

End of block: The CR code. The hexadecimal code 0Dh.

	Start	High Address	Low Address	Data																End
ASCII	@	0 a 9	0 a 9	R	L	d7	d6	d5	d4	d3	d2	d1	d0	R	R	r0	r1	C	c0	CR
HEXA	40	30 a 39	30 a 39	52	4C									52	52			43		0D

Examples:

Request for the display value to be sent to a unit located at address 01 of the network.

	Start	High Address	Low Address	Code to get data	End
ASCII	@	0	1	L	CR
HEXA	40	30	31	4C	0D

Reply from the display.

Received value = 2.514

Relay 1 = ON. Relay 2 = OFF.

Digits colour: Red.

	Start	High Address	Low Address	Data																End
ASCII	@	0	1	R	L	d7	d6	d5	d4	d3	d2	d1	d0	R	R	r0	r1	C	c0	CR
HEXA	40	30	31	52	4C	20	20	20	32	2E	35	31	34	52	52	31	30	43	30	0D

Other example replay

Received value: -3.119

Relay 1 = OFF. Relay 2 = OFF.

Digits colour: Green

	Start	High Address	Low Address	Data																End
ASCII	@	0	1	R	L	d7	d6	d5	d4	d3	d2	d1	d0	R	R	r0	r1	C	c0	CR
HEXA	40	30	31	52	4C	20	20	2D	33	2E	31	31	39	52	52	30	30	43	31	0D

6. RELAY OUTPUT OPTION AND COLOUR OPTION.

There is a great link between relay output option and colour option because both uses the same alarm levels defined in the relay option, although is possible to have the colour option without the relay output option.

The equipments which possess the relay output option (**DN-1_9APR**. See Section 1.1) may generate control and alarm signals for their use by other units. The trigger level of the relay can be delayed with a timer or by a hysteresis value. The activation of the relay may be programmed so that it acts above or below the programmed trigger level.

The equipments which posses the colour option may be programmed to display the value using colour red, green or yellow.

The relation between the display colour and the display value is given by the relay output set point. With 2 relays is possible to define 4 levels and 4 parameters.

- Parameter **nr** : No relays ON.
- Parameter **r1** : Relay 1 ON.
- Parameter **r2** : Relay 2 ON.
- Parameter **r3** : Relays 1 and 2 ON.

For each parameter the three colours (Red, green or yellow) may be programmed.

Relay output option parameters are detailed in section 6.4.

6.1 Characteristics of the relay output option.

SPDT contact.

Maximum current:

Resistive load5A

Inductive load5A

Maximum voltage:60V AC/DC

6.2 Wiring of relay output

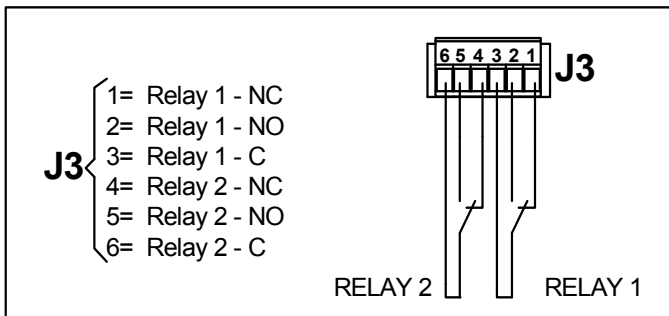

Position of **J3** connector on page 13

6.3 Modifying parameters of relay output option.

In order to configure the parameters, one must access the parameter modifying menu according to how it is detailed in Section 4.3.2. The parameters of the serial line are accessed from the rLS symbol.

6.4 Parameters description of relay output.

rLS

Selection menu for relay output. Upon pressing ENTER the menu is accessed.

rL1

Relay 1 configuration. After 2 seconds, the last value programmed is displayed and permitted to be modified. Upon pressing ENTER the value is validated and the next parameter is accessed. Each one of the two digits has a distinct function.

Left digit		Right digit	
0	On if Value > Setpoint	0	Delay
1	On if Value < Setpoint	1	Hysteresis
2	Always off		

dL1

Delay time or hysteresis value of relay 1. After 2 seconds, the last value programmed is displayed and permitted to be modified. Upon pressing ENTER the value is validated and the next parameter is accessed.

SE1

Set point value of relay 1. After 2 seconds, the last value programmed is displayed and permitted to be modified. Upon pressing ENTER the value is validated and the next parameter is accessed.

rL2

Relay 2 configuration. After 2 seconds, the last value programmed is displayed and permitted to be modified. Upon pressing ENTER the value is validated and the next parameter is accessed. Each one of the two digits has a distinct function.

Left digit		Right digit	
0	On if Value > Setpoint	0	Delay
1	On if Value < Setpoint	1	Hysteresis
2	Always off		

dL2

Delay time or hysteresis value of relay 2. After 2 seconds, the last value programmed is displayed and permitted to be modified. Upon pressing ENTER the value is validated and the next parameter is accessed.

SE2

Set point value of relay 2. After 2 seconds, the last value programmed is displayed and permitted to be modified. Upon pressing ENTER the value is validated and the next parameter is accessed.

Output relay option

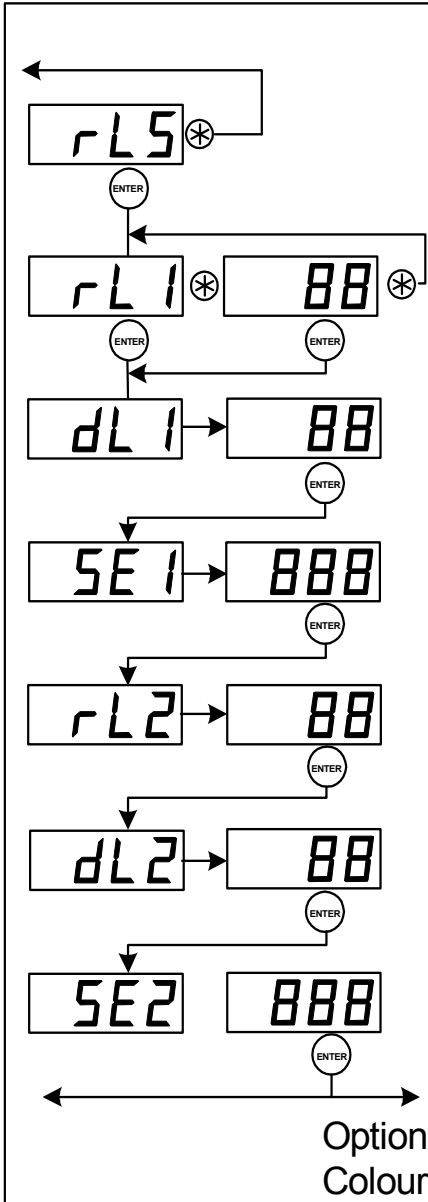

6.5 Parameters description of colour option.

If you have the colour option the set up colour parameters will be shown after the relay output parameters. It is not necessary to have the relay output option to use the colour option although both use the same parameters.

The programmed colour is the colour that you see.



Colour when no one relay ON. To change the colour push (+) key. Upon pressing ENTER the value is validated.



Colour when relay 1 is ON. To change the colour push (+) key. Upon pressing ENTER the value is validated.



Colour when relay 2 is ON. To change the colour push (+) key. Upon pressing ENTER the value is validated.



Colour when relay 1 and 2 are ON. To change the colour push (+) key. Upon pressing ENTER the value is validated.

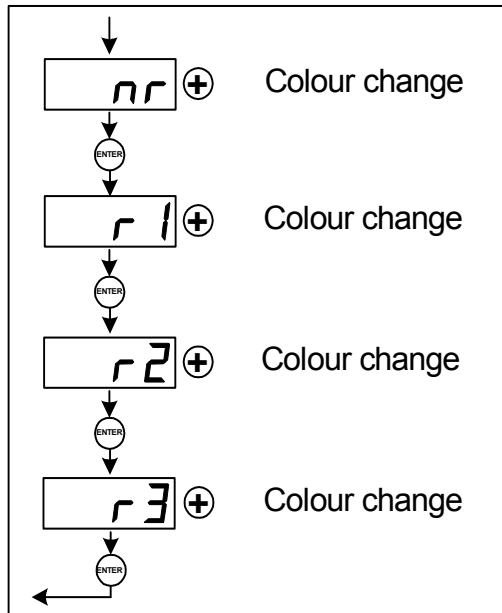

DECLARATION OF CONFORMITY



Tetralec Electronica Industrial, S.L.
c/ Severo Ochoa, 80
Polígono Industrial Font del Ràdium
08403 Granollers

As the manufacturer of the brand **LARTET** equipment:

Numeric display with serial interface.

Model: DN-109AP in all versions.

Model: DN-119AP in all versions.

Model: DN-129AP in all versions.

Model: DN-189AP in all versions.

We state under own responsibility that the above mentioned product complies with the following European:

Regulation: 73/23/CEE Regulation of low voltage and modification 93/68/CEE
Standard UNE-EN61010-1 Security in electric equipment

Regulation: 89/336/CEE Regulation of electromagnetic compatibility and modifications 92/31/CEE and 93/68/CEE

Standard UNE-EN61000-6-4 Generic emission standard. Industrial environment

Standard UNE-EN61000-6-2 Generic immunity standard. Industrial environment

Granollers, 15 of June 2009

A handwritten signature in blue ink, appearing to read 'J. Bisbe', with a long horizontal stroke extending to the right.

Josep M^a Bisbe
Technical Manager